

Issues of the structure and properties of materials used in electrical and electronic equipment are outlined. Electrophysical effects and phenomena in conductors, dielectrics, semiconductors, and magnetic materials are considered. Considerable attention is paid to kinetic effects in semiconductors, properties of basic semiconductor materials, metals, and nanomaterials. Examples of practical application of the considered materials are given.
For students of technical universities specializing in electrical engineering, electronic engineering, automation and radio engineering.

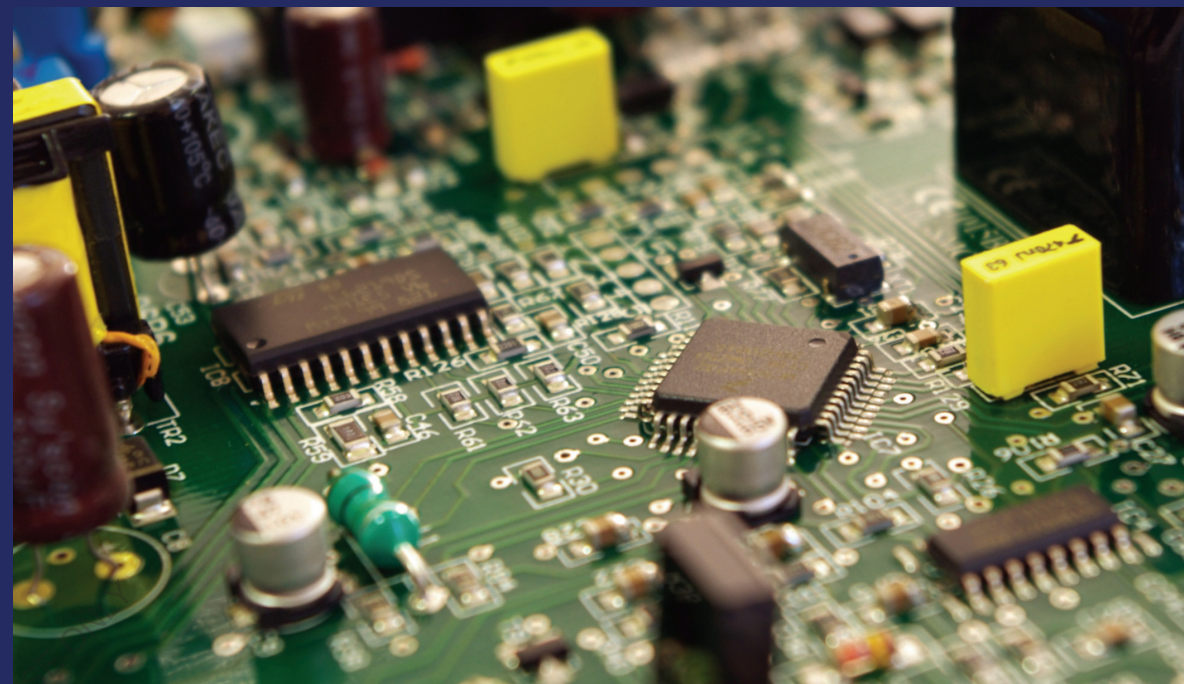

Mykola Gorbachuk

ELECTROTECHNICAL MATERIALS

Tutorial

Mykola Gorbachuk holds a PhD in Physics and Mathematics with a specialization in semiconductor and dielectric physics. He works in the Department of Applied Physics and Higher Mathematics at the Kyiv National University of Technology and Design, Ukraine.



Mykola Gorbachuk



Mykola Gorbachuk

ELECTROTECHNICAL MATERIALS

FOR AUTHOR USE ONLY

Mykola Gorbachuk

ELECTROTECHNICAL MATERIALS

Tutorial

FOR AUTHOR USE ONLY

LAP LAMBERT Academic Publishing

Imprint

Any brand names and product names mentioned in this book are subject to trademark, brand or patent protection and are trademarks or registered trademarks of their respective holders. The use of brand names, product names, common names, trade names, product descriptions etc. even without a particular marking in this work is in no way to be construed to mean that such names may be regarded as unrestricted in respect of trademark and brand protection legislation and could thus be used by anyone.

Cover image: www.ingimage.com

Publisher:

LAP LAMBERT Academic Publishing

is a trademark of

Dodo Books Indian Ocean Ltd. and OmniScriptum S.R.L publishing group

120 High Road, East Finchley, London, N2 9ED, United Kingdom

Str. Armeneasca 28/1, office 1, Chisinau MD-2012, Republic of Moldova,
Europe

Printed at: see last page

ISBN: 978-620-3-46212-8

Copyright © Mykola Gorbachuk

Copyright © 2024 Dodo Books Indian Ocean Ltd. and OmniScriptum S.R.L
publishing group

FOR AUTHOR USE ONLY

Introduction

Electrotechnical materials - current state, development prospects

Modern scientific and technological progress is closely linked to the development and mastery of new materials. It is materials that have become a key link that determines the success of many engineering solutions in the creation of electrical equipment and electronic devices. Therefore, the study of materials is given a significant place.

The intensive development of science and technology is impossible without solving the problem of improving the quality and cost-effectiveness of materials, the material basis of any product. New materials appear as a result of a preliminary in-depth study of the economic, functional and consumer properties of various substances, as well as the technology of their production and processing.

Practice constantly puts forward diverse and increasingly stringent requirements for the properties and combination of properties in materials. Accordingly, the number and range of materials is growing. Today, the number of materials used in electrical engineering for various purposes is in the tens of thousands.

FOR AUTHOR USE ONLY

Chapter 1. General information about electrical materials

1.1. Classification of electrical materials

Electrical materials are materials characterized by certain properties in relation to the electromagnetic field and used in technology based on these properties. Different properties of materials are affected by electric or magnetic fields separately or in combination.

According to their behavior in a magnetic field, electrical materials are divided into strongly magnetic (magnets) and weakly magnetic. The former are particularly widely used in engineering due to their magnetic properties.

According to their behavior in an electric field, materials are divided into conductors, semiconductors, and dielectrics. Most electrical materials can be classified as weakly magnetic or practically non-magnetic. However, even among magnets, a distinction should be made between conductors, semiconductors, and practically nonconductors.

Conductors are materials whose main electrical property is strong electrical conductivity. Their use in technology is mainly due to this property, which determines the high specific electrical conductivity at normal temperature. Semiconductors are materials that intermediate between conductive and dielectric materials in terms of conductivity. Dielectrics are materials whose main electrical property is the ability to polarize and in which an electrostatic field can exist. Conventionally, materials with a resistivity of $\rho < 10^{-5}$ Ohm·m are considered conductors, and materials with a resistivity of $\rho > 10^8$ Ohm·m are considered dielectrics. Depending on the structure and composition of the materials, as well as on their operating conditions, the resistivity of semiconductors can vary within the range of 10^{-5} - 10^8 Ohm·m. Metals are good conductors of electric current. It is difficult to draw a clear line between the resistivity values of different materials. For example, many semiconductors behave like dielectrics at low temperatures. At the same time, dielectrics can exhibit the properties of semiconductors when heated to high temperatures. The qualitative difference is that for metals, the conducting state is the ground state, while for semiconductors and dielectrics it is the excited state.

From the point of view of the band theory, metals are considered to be materials with no band gap ($E_g = 0$), semiconductors with $E_g = 0-2$ eV, and dielectrics with $E_g \geq 2$ eV.

A real dielectric is closer to the ideal dielectric the lower its specific conductivity and the less pronounced its slow polarization mechanisms associated with the dissipation of electrical energy and heat generation.

Both passive and active properties of dielectrics are used in technology. The passive properties of dielectric materials are used when they are used as electrical insulating materials and as dielectrics for conventional capacitors. Electrical insulating materials are dielectrics that prevent the leakage of electric charges, i.e., they are used to separate electrical circuits from each other or conductive parts of devices, instruments and apparatus from conductive parts. In these cases, the dielectric constant of the material does not play a special role. If a material is used as a dielectric for a

capacitor of a certain capacity and smallest dimensions, then, all other things being equal, it is desirable that this material have a high dielectric constant.

Active dielectrics include ferroelectrics, piezoelectrics, pyroelectrics, electroluminescents, materials for emitters and gates in laser technology, and electretes.

The development of radio engineering has led to the creation of materials that combine specific high-frequency properties with the required physical and mechanical parameters. Such materials are called high-frequency materials.

To understand the electrical, magnetic, and mechanical properties of materials, as well as the causes of aging, knowledge of their chemical and phase composition, atomic structure, and structural defects is required.

1.2. Types of chemical bonds in substances

A molecule is an elementary particle that possesses the properties of one or another substance. A molecule consists of atoms. In turn, the main elementary particles from which all known substances (their molecules, atoms) are built are protons, neutrons and electrons. Protons and neutrons make up atomic nuclei; electrons fill the shells of the atom, compensating for the positive charge of the nucleus.

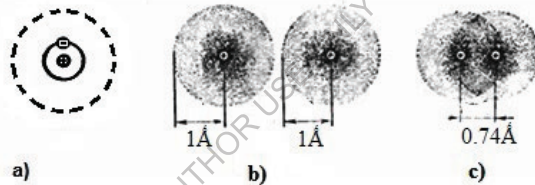

Fig. 1.1. Structure of the hydrogen atom and molecule H_2 .

For example, a hydrogen atom consists of one proton and one electron. In a simple planetary model of the atom, this electron orbits the nucleus of the atom (fig. 1.1, a). In quantum mechanics, the motion of the electron is described by a wave function that has spherical symmetry in an isolated hydrogen atom, so that the electron charge is distributed, forming a blurry cloud (fig. 1.1, b).

There are several types of chemical bonds between atoms.

Homeopolar (covalent) bond. In this bond, the unification of atoms into a molecule is achieved by electrons that become common to pairs of atoms. The density of the negatively charged electron cloud between the positively charged nuclei becomes the highest.

An example of a homeopolar or covalent bond is the H_2 molecule (fig. 1.1, c). The overlap of electron clouds, which leads to electron crowding, is accompanied by a significant redistribution of the electron density and a change in the energy of the system. When electrons are socialized, electron clouds are drawn into the space between the nuclei. The emergence of a state with an increased electron charge density in the inter-nuclear space leads to the emergence of attractive forces.

The homeopolar bond is based on an exchange interaction or exchange effect caused by the exchange of electrons between atoms and has a purely quantum nature.

The forces of such interaction are called exchange forces, and their energy is called exchange energy. The most important feature of the exchange forces is their strong dependence on the direction of the electron spins that provide the bond between the interacting atoms. The bond will be strong only if the spins are antiparallel. Homeopolar bonds are oriented in a certain way in space and are formed only between the closest neighboring atoms.

Molecules with homeopolar bonds can be nonpolar or polar (dipolar), respectively, with symmetrical or asymmetrical structure. Molecules in which the centers of positive and negative charges coincide are called nonpolar. If the centers of charges of opposite sign do not coincide and are located at some distance from each other, such molecules are called polar or dipolar. Examples of nonpolar and polar molecules are shown in fig. 1.2.

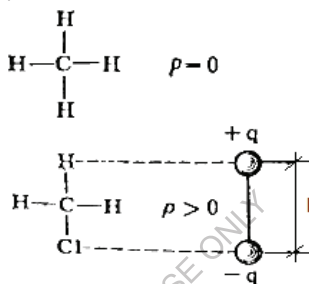

Fig. 1.2. Polar ($p > 0$) and nonpolar ($p = 0$) molecules (p is the dipole moment).

Homeopolar bonding is typical for organic molecules. However, it can also be observed in solids of inorganic origin if their crystal lattice consists of atoms. Examples of such substances are diamond, silicon, germanium, silicon carbide, etc. The structure of diamond is shown in Fig. 1.3, which shows how each atom forms four bonds with its nearest neighbors.

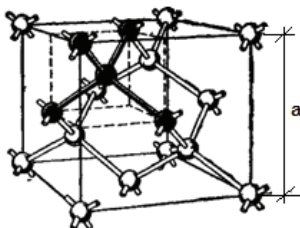

Fig. 1.3. Model of the diamond lattice.

The covalent bond is characterized by high strength. This is confirmed by the high hardness and high melting point of such substances as diamond and silicon carbide.

Heteropolar (ionic) bonding occurs as a result of the transfer of valence electrons from a metal atom to a metalloid atom and the electrostatic attraction of differently charged ions to each other. This type of chemical bond is realized in ionic crystals. A typical example of ionic crystals is halide salts of alkali metals. Fig. 1.4

shows the structures of sodium chloride and cesium chloride crystals. Ionic lattices are characterized by a high coordination number, which shows the number of nearest ions of the opposite sign. For example, for NaCl crystals, the coordination number is 6, and for CsCl crystals, it is 8.

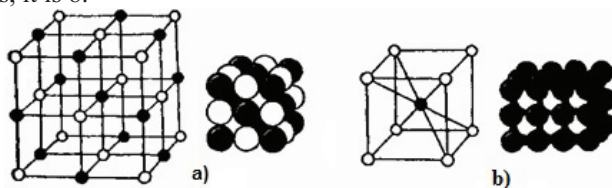

Fig. 1.4. Structures of sodium chloride (a) and cesium chloride (b) crystals.

The ability of an atom to capture an electron when forming a chemical bond is characterized by its electronegativity. An approximate measure of the electronegativity of atom x is the half-sum of the ionization energy E_i and the electron affinity E_c

$$x = 0,5 (E_i + E_c)$$

Alkali metal atoms have the lowest electronegativity, as they easily give up an electron and have low affinity energy. On the contrary, halogen atoms have the highest electronegativity, which readily accept an electron to complete the outer electron shell. The greater the difference in electronegativity of the atoms involved in the formation of a chemical bond, the greater the degree of ionicity of the compound.

Metallic bonding exists in systems constructed from positive atomic backbones in an environment of free collectivized electrons (fig. 1.5, a). The attraction between the positive atomic backbones and electrons determines the integrity of the metal.

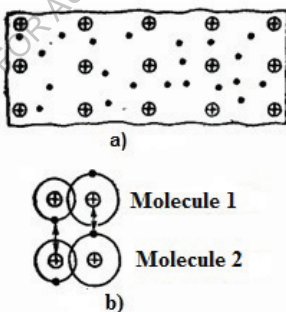

Fig. 1.5. a) metal bond, b) scheme of molecular bond formation.

Metallic bonds can be considered to some extent as covalent bonds, since they are based on the sharing of external valence electrons. The specificity of the metallic bond is that all atoms of the crystal participate in the electron sharing, and the shared electrons are not localized near their atoms, but move freely within the entire lattice, forming an "electron gas". Having no localized bonds, metal crystals (unlike ionic crystals) do not collapse when the positions of their atoms change, i.e. they are

characterized by plasticity (ductility) under deformation. Due to the presence of free electrons, metals have high electrical and thermal conductivity.

Molecular bonding, or Van der Waals bonding, is observed between molecules in substances with covalent interaction within the molecules. In this case, the presence of intermolecular attraction is possible with the coordinated movement of valence electrons in neighboring molecules (fig. 1.5, b). At any given time, the electrons should be as far away from each other as possible and as close as possible to positive charges (nuclei). Then the forces of attraction of valence electrons by the nucleus of a neighboring molecule are stronger than the forces of mutual repulsion of electrons of the shells of these molecules.

Such an attraction between fluctuating electric dipoles is called the dispersion interaction. The Van der Waals bond is the most universal, it occurs between any particles, but it is the weakest bond, its energy is about two orders of magnitude lower than the energy of ionic and covalent bonds. Since the dispersion interaction is very weak, molecular bonds are clearly visible only when they occur between atoms or molecules. Molecular bonding is easily destroyed by thermal motion. Therefore, molecular crystals have low melting points (e.g., paraffin has a melting point of 50-52 °C).

1.3. Crystals. The structure of the crystal lattice. Miller's indices

Atoms in single crystals are arranged in an orderly fashion. Such an ordered arrangement of atoms is called a crystal lattice. The most characteristic property of the single crystal lattice is translational symmetry. Each node of the lattice can be described by the vector \vec{r} .

$$\vec{r} = h\vec{a} + k\vec{b} + l\vec{c} \quad (1.1),$$

where h, k, l are integers.

The length of the vectors $\vec{a}, \vec{b}, \vec{c}$ depends on the structure of the crystal lattice. The area formed by the three vectors $\vec{a}, \vec{b}, \vec{c}$ is called a unit cell. A macroscopic crystal is formed by periodic repetition of numerous unit cells. There are different ways to choose the unit cells. According to the way the nodes of the crystal lattice are arranged, there are 14 structures called Bravais lattices. Whereas when $\vec{a}, \vec{b}, \vec{c}$ is the length of the main vectors that form a unit cell, Bravais lattices are classified by the size of the angles between these vectors. Figure 1.6 shows two of the simplest Bravais lattices: a simple cubic lattice (a) and a face-centered cubic lattice (b):

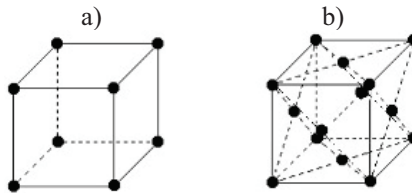

Fig. 1.6. Bravais lattice - simple cubic (a) and face-centered cubic (b).

The main semiconductors of the 4th group (Si, Ge) of the periodic system crystallize in the so-called diamond-like lattice (fig. 1.3). In this case, the nearest four atoms are placed at the same distance from each other and form a regular tetrahedron (fig. 1.7):

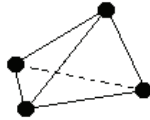

Fig. 1.7. Model of the arrangement of atoms in a diamond-like lattice.

Since crystals have a periodic structure, their properties differ for different crystallographic directions and planes. This is manifested in the electrical properties of single-crystal semiconductors, in their etching, epitaxy, diffusion, oxidation, etc. To designate crystallographic directions and planes in single crystals, Miller indices are used, which are defined as follows (fig. 1.8):

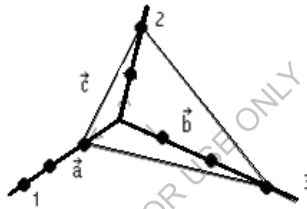

Fig. 1.8. Definition of Miller's indices

The position of one of the atoms is chosen as the origin, from which the coordinate axes are drawn in the directions of the principal vectors.

The points of intersection of the imaginary crystallographic plane with these coordinate axes are expressed as integers, taking the lengths of the principal vectors as a unit. In the figure, these intersection points are shown by the numbers 1, 3, 2.

The inverse of these integers is multiplied by their minimum common denominator, obtaining a simple ratio of integers.

If these numbers are denoted by h, k, l , then their expression in parentheses (hkl) will be the Miller indices for this plane. For our figure we get:

$$\left(\frac{1}{1}, \frac{1}{3}, \frac{1}{2}\right) \cdot 6 = (623)$$

For crystals (single crystals), each of the planes, for example, (110) , (100) , (111) , in any cross-section of the crystal has the same properties. The technology of manufacturing semiconductor devices, especially such operations as etching, diffusion, and oxidation, has its own peculiarities depending on the orientation. Therefore, these features are taken into account when manufacturing semiconductor devices.

1.4. Difference between ideal and real crystals. Lattice vibrations and crystal defects

In real crystals, the lattice is not perfect and has various crystal defects. Therefore, in many cases, the electrical and optical properties of semiconductor materials deviate from those calculated for ideal crystals. In the manufacture of semiconductor devices, such as transistors, these deviations from the ideal crystal are taken into account and controlled to obtain the desired device characteristics.

There are various types of deviations from the ideal crystal structure. If atoms are placed in the nodes of an ideal crystal lattice, then under the influence of thermal energy in a certain temperature range they oscillate relative to the position of stable equilibrium. Electrons are scattered by these thermal vibrations. These vibrations are called lattice vibrations or phonons. If we consider the vibrations of the atoms of a crystal as a whole, then due to the periodicity of the crystal structure, these vibrations can be represented as superposition of vibrations of a set of harmonic oscillators. Each such oscillator can be considered as a single quasiparticle called a phonon.

In addition to lattice vibrations, crystal defects include non-periodic arrangement of atoms in a crystal - lattice defects. Point defects play an important role in the mechanisms of electrical conductivity of semiconductors. Point defects can combine to form another type of defects - dislocations. Nowadays, great progress has been made in producing defect-free crystals, especially silicon.

Impurity atoms introduced into a semiconductor crystal determine both the type and magnitude of its electrical conductivity and other properties. By controlling the introduction of impurity atoms, various electrophysical characteristics of materials used to make transistors and large integrated circuits (VLSI) are obtained.

If the Si atom in the silicon crystal lattice is replaced by an element of group V, such as phosphorus (P), then the outer shell of the P atom will have one extra electron that will move freely through the crystal, increasing its electrical conductivity. When a Group III element, such as boron (B), is added to silicon, one valence electron will be missing. This lack of an electron, i.e., from the point of view of band theory, a hole located near the ceiling of the valence band and which can move freely through the crystal, also affects its electrical conductivity.

In the first case, the electrical conductivity is determined by electrons - particles that carry a negative charge; such semiconductors are called n-type semiconductors, and the mixture atoms that supply the crystal with extra electrons are called donors.

In the second case, the electrical conductivity of semiconductors is determined by holes that carry a positive charge, and they are called p-type semiconductors, and the impurity atoms that supply the holes are called acceptors.

In such a semiconductor as GaAs, for example, the donors are elements of group VI, such as sulfur (S) and tellurium (Te), and the acceptors are elements of group II, such as beryllium (Be) and zinc (Zn).

1.5. Structure of energy zones

Electrons are known to have wave properties. The theory that describes these properties was developed in Schrödinger wave mechanics. In this theory, the wave function ψ is used to represent a unified system of wave and particle properties. The

expression $\psi^*\psi$ is called the probability density function. The physical meaning of the wave function is that the expression $\psi^*\psi dv$ determines the probability of appearance (or existence) of a particle described by the function ψ in a time interval t in a volume dv . In other words, the probability of an electron's existence in a time t in a volume dv is determined by the square of the amplitude of its wave function.

According to wave mechanics, there is a relation between the quasi-momentum p of a free particle and the wave vector k :

$$p = \hbar k \quad , \quad (1.2)$$

where $\hbar = \frac{h}{2\pi}$.

The energy of a free particle is related to its mass by the formula:

$$E = \frac{\hbar^2 k^2}{2m} \quad . \quad (1.3)$$

Let's compare electrons in a vacuum with their state in a single crystal.

In an ideal single crystal, the atoms are periodically spaced at an appropriate distance from each other. Atoms consist of nuclei that have a positive charge and electrons with an equivalent negative charge. In crystals, such as silicon, the electrons of the outer shell orbit not only their own nucleus but also neighboring atoms and form covalent interatomic bonds. Such electrons are called valence electrons.

At a certain temperature, some of the valence electrons acquire additional force energy, are released from the bond with one atom, and begin to move throughout the crystal, i.e., ionization occurs. Such electrons are called free or conduction electrons. For a single (lone) atom, the energy levels of electrons are discrete. In a crystal, however, the number of atoms exceeds 10^{22} cm^{-3} , so continuous energy bands are formed under the influence of neighboring atoms. A diagram of the formation of energy bands when atoms approach is shown in figure 1.9:

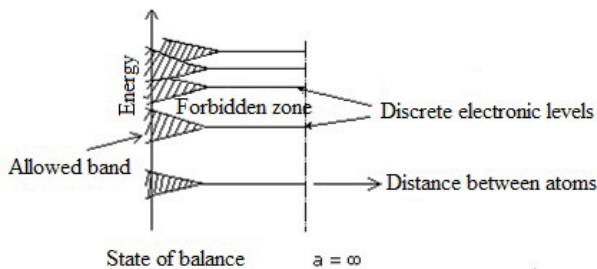

Fig. 1.9. Scheme of energy zones formation.

The discrete levels of an individual atom expand into energy bands as the interatomic distances in the crystal decrease.

The shaded areas can contain electrons, so they are called the allowed bands. There are no electrons in the gaps between these areas. These energy regions are called

forbidden bands. The presence of forbidden and allowed bands is the main factor determining the electrical and optical properties of solids.

The conclusion about the presence of energy bands in crystals can be reached by other considerations. In crystals, a periodically varying potential is formed due to the positive charges of atomic nuclei arranged in a certain sequence and the negative charges of electrons surrounding these positive charges. For electrons in such a periodic potential, there is no longer a continuous distribution of energy. This is where the wave properties of electrons come into play. The simplest model that explains the wave properties of electrons in a periodic potential is the Cronig-Penney model:

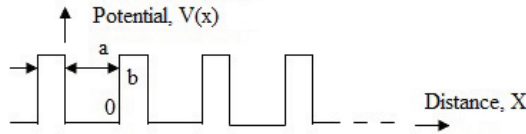

Fig. 1.10. Rectangular one-dimensional periodic potential.

Let us determine the relationship between the electron energy and the wave vector (or momentum) in a rectangular one-dimensional periodic potential (fig. 1.10)

The Schrödinger equation for this case is written in the form:

$$\frac{d^2\psi(x)}{dx^2} + \frac{2m}{\hbar^2}(E - V(x))\psi(x) = 0 \quad , \quad (1.4)$$

where $V(x)$ is the periodic potential, $\psi(x)$ is the electron wave function.

The wave function of an electron in a periodic potential $V(x)$ is expressed by the Bloch function:

$$\psi(x) = e^{ikx}U(x) \quad , \quad (1.5)$$

where $U(x)$ varies similarly to $V(x)$.

If we solve Schrödinger's equation (1.4) with this in mind, we obtain the relationship between the electron energy $E(k)$ and the wave vector k (fig. 1.11(a)):

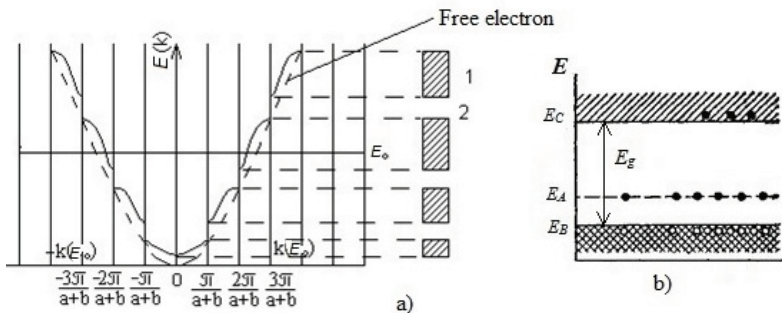

Fig. 1.11. a - dependence of the electron energy E on the wave vector k , b - band structure of a p-type semiconductor (acceptor)

In the graph, discontinuities in the function $E(k)$ appear at points $\frac{\pi}{a+b}$, i.e., allowed and forbidden energy bands appear, as shown on the right side of the figure.

When explaining many electrophysical properties of semiconductors, elements of the band structure are used in the form shown in Fig. 1.11(b). Here, E_B is the upper energy level of the valence band, E_C is the bottom of the conduction band, E_A is the energy level formed by the acceptor impurity, and E_g is the width of the band gap. In the above model of the band structure, conductivity and other kinetic effects are explained by the presence of holes (absence of electrons) in the valence band and electrons in the conduction band. The holes in the valence band are formed due to the transition of electrons to the acceptor level and to the conduction band.

1.6. Brillouin and reduced zones

If the starting point of the graph of the function $E(k)$ (see fig. 1.11) is moved to the points of $\frac{2\pi n}{(a+b)}$, $n = \pm 1, \pm 2, \dots$, we will get completely coincident sections of the corresponding graphs. This corresponds to the fact that the transfer of an electron in the space of a periodic potential or a real crystal at a distance $(a+b)$ is fully adequate to the transfer at $\frac{2\pi n}{(a+b)}$ in k -space. Therefore, to eliminate the ambiguity of the definition of the electron wave vector in the crystal, let us assume that the function $E(k)$ is defined only in the region $-\frac{\pi}{(a+b)} \leq k \leq \frac{\pi}{(a+b)}$ in the figure. The sections of the graph of the function $E(k)$ located outside this region are transferred with an appropriate change of sign to the middle of this section and we obtain the graph of the function $E(k)$ shown in figure 1.12.

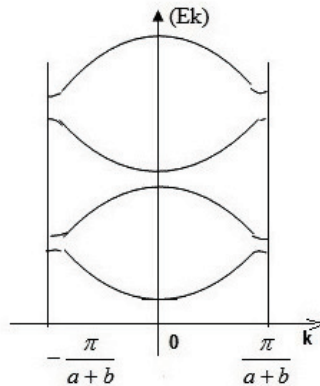

Fig. 1.12. The first Brillouin zone

This transformation is called the representation of reduced zones, and the $-\frac{\pi}{a+b} \leq k \leq \frac{\pi}{a+b}$ domain is called the first Brillouin zone.

Similar considerations are valid for two-dimensional and three-dimensional crystal lattices. In real three-dimensional crystals, it depends on their crystal structure, for example, on the type of symmetry. For example, silicon and GaAs have face-centered cubic lattices, so their Brillouin bands have the same shape.

The $E(k)$ function for real crystals is three-dimensional and in most cases it is located only within the first Brillouin band. Such a three-dimensional function $E(k)$ is called the energy band structure.

1.7. Effective mass, electrons and holes

The energy and momentum of electrons in a crystal are related to each other by a complex function (the structure of energy bands), which depends on the structure of the crystal lattice.

The structure of energy bands determines the electro-optical properties of real crystals. Therefore, when designing semiconductor devices with the desired characteristics, one should choose a semiconductor with the most appropriate energy band structure.

Let's consider the movement of electrons in an electric field in a crystal - an electric current. We will assume that all electrons localized in a certain region are described by a single wave function, which we call a wave packet. The velocity of a wave packet of electrons is the group velocity V_g :

$$V_g = \frac{dw}{dk} = \frac{1}{\hbar} \cdot \frac{dE}{dk} \quad , \quad (1.6)$$

where w – corner frequency, $E = \hbar w$

The energy acquired by an electron in an electric field of intensity \mathbf{E} over a period of time dt when moving a distance dx is equal to:

$$dE = -e\mathbf{E}dx = -e\mathbf{E}V_g \cdot dt \quad . \quad (1.7)$$

From the expressions (1.2), (1.6), (1.7) it is possible to obtain:

$$\frac{dp}{dt} = -e\mathbf{E} = F \quad , \quad (1.8)$$

where F – the force acting on an electron in an electric field \mathbf{E} .

Let us show that (1.8) is equivalent to Newton's second law in classical mechanics. Let us differentiate 1.6 with respect to t and, using (1.8), we obtain:

$$\frac{dV_g}{dt} = \left(\frac{1}{\hbar^2} \cdot \frac{d^2E}{dk^2} \right) \cdot F \quad . \quad (1.9)$$

If you enter the notation $m^* \equiv \frac{\hbar^2}{(d^2E / dk^2)}$. (1.10)

Then we can write (1.9) $m^* \cdot \frac{dV_g}{dt} = F$. (1.11)

Thus, (1.8) does indeed correspond to Newton's second law. The value m^* is called the effective mass of the electron in the crystal.

For real three-dimensional crystals, k is the wave vector of the crystal, and m^* is a tensor quantity (depending on the direction in k space).

Suppose that the movement of electrons and, accordingly, the electric current occurs within one allowed zone. If the velocity of the i th electron is V_i , then the current in the volume V can be determined:

$$I = -\frac{e}{V} \sum_i V_i \quad , \quad (1.12)$$

where Σ is the addition across all electrons in the band.

If the zone is completely filled with electrons, the current through it $I = 0$. This is due to the fact that the shape of the zone is symmetrical to the axis at $k = 0$, and if we integrate V_i (see 1.6) inside the zone, the positive and negative parts of the integral cancel each other out.

Suppose that the electrons located near the top of the band leave the band under the influence of thermal energy, forming an electron-free (or vacant) state. Then from (1.12) we can obtain:

$$I = -\frac{e}{V} [\sum_i V_i - \sum_h V_h] \quad , \quad (1.13)$$

where V_h is the velocity of vacant states in the zone, Σ is the sum of the velocities of all states in the zone.

That is, at $\sum_i V_i = 0$ we get: $I = \frac{e}{V} \sum_h V_h$. (1.14)

It follows from (1.14) that states not filled with electrons also contribute to the electric current. These states move like particles carrying a positive charge and are called holes.

Since the flow of electric current in semiconductors involves both electrons and holes, both are charge carriers.

1.8. Structure of silicon energy bands

At a temperature of absolute zero, electrons fill the zone with energy $E \leq 0$, which is called the valence zone. The band with $E > 0$ is completely free. However, as the temperature rises, some of the electrons in the valence band are excited, and they partially fill the band with $E > 0$. These electrons participate in the electrical conductivity of the semiconductor, so this zone is called the conduction band.

If a section parallel to the k -axis is drawn just above the edge of the conduction band, it will define two points that lie on the $\langle 100 \rangle$ axis in silicon. In three-dimensional k -space, these points are transformed into isoenergetic surfaces. These surfaces are ellipsoids of rotation with the major axis in the directions $\langle 100 \rangle$ for silicon and, for example, $\langle 111 \rangle$ for germanium. Silicon has six equivalent energy minima (valleys) and, for a given energy value, six ellipsoids in k -space (fig. 1.13):

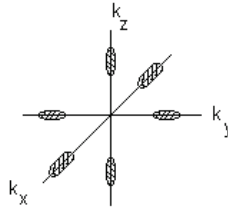

Fig. 1.13. Isoenergetic surfaces of the conduction band of silicon

Similar sections carried out near the edge of the valence band give pairs of points of equal energy, which in three-dimensional k -space turn into corrugated spheres (fig. 1.14) centered at $k = 0$.

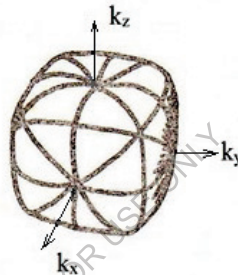

Fig. 1.14. Isoenergetic surfaces in k -space near the ceiling of heavy holes in the valence band of silicon and germanium

The valence band ceiling consists of two energy bands of different curvature, which close at $k = 0$, and a third band located below. An enlarged view of the region near the valence band ceiling is shown in figure 1.15:

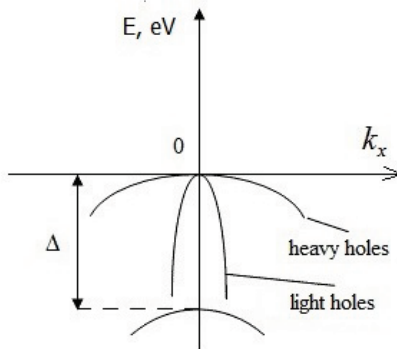

Fig. 1.15. The valence band of silicon. Energy zones

The effective mass of carriers in the valence band consists of three scalar quantities. In the zone with a small curvature radius, there are so-called light holes with

an effective mass m_l^* , and in the zone with a larger curvature radius, there are heavy holes with an effective mass m_h^* . The third zone, separated from the other two by an energy gap Δ , is formed by the interaction of electron spins with their orbital magnetic moments. This effect is called spin-orbit splitting. In silicon, the value of Δ is 0.035 eV, and at room temperature, holes fill this third band.

In the energy region between the bottom of the conduction band and the ceiling of the valence band, there are no electrons. This region is called the band gap. Materials in which the forbidden band is absent due to the mutual overlap of the permitted energy bands are electrically conductive even at absolute zero temperature, i.e., they are metals.

The structure of energy bands depends on pressure and temperature, since pressure and temperature change the lattice constant.

FOR AUTHOR USE ONLY

Chapter 2. Conductors. Electrophysical properties of conductors

2.1. General information

Electrical current can be carried by solids, liquids, and, under appropriate conditions, gases.

Metals, metal alloys and some modifications of carbon are solid conductors. Metals conduct electricity and heat well. In electronic engineering, metals play an important role.

Liquid conductors include molten metals and electrolytes. As a rule, the melting point of metals is high. At normal temperatures, only mercury, which has a melting point of -39°C , can be used as a liquid metal conductor. Gallium also has a melting point close to normal (29.8°C).

The mechanism of current flow through metals in the solid and liquid state is caused by the movement of free electrons, which is why they are called conductors with electronic electrical conductivity or conductors of the first kind.

Electrolytes, or conductors of the second kind, are solutions of acids, alkalis and salts, as well as melts of ionic compounds. The passage of current through such conductors is associated with the transfer of parts of molecules (ions) along with electric charges, as a result of which the composition of the electrolyte gradually changes, and electrolysis products are released at the electrodes.

All gases and vapors, including metal vapors, are non-conductive at low electric field strengths. However, if the field strength is above a certain critical value, which ensures the onset of shock and photoionization, the gas can become a conductor (electronic and ionic conductivity). Strongly ionized gas under certain conditions becomes a medium called plasma.

2.2. Electrical conductivity of metals

The classical electronic theory of metals, developed by Drude and Lorentz, is based on the idea of an electron gas consisting of free (collectivized) electrons. The electron gas is attributed the properties of an ideal gas, i.e., the movement of electrons obeys the laws of classical statistics. If we assume that the atoms in a metal are ionized once, the concentration of free electrons will be equal to the concentration of atoms and can be calculated by the formula:

$$n = \frac{\rho}{A} N_0, \quad (2.1)$$

where ρ is the density of the material; A is the atomic mass; N_0 is the Avogadro number.

In the course of general physics, using the kinetic theory of ideal gases to consider the directional movement of electrons in an electric field, the formula for the current density is derived:

$$J = \frac{e^2 n \bar{l}}{2m_0 \bar{U}} E = \sigma E, \quad (2.2)$$

where \bar{l} – is the average free path length of an electron, \bar{U} – average speed.

That is, the current density is proportional to the electric field strength, which is the analytical expression of Ohm's law.

The derivation of formula (2.2) cannot be considered absolutely rigorous, since the motion of only one electron was taken into account, and the conclusions applied to all free electrons. It would be more correct to consider the effect of the electric field on the entire set of free electrons, whose total momentum changes both under the action of the field and under the action of collisions with the nodes of the crystal lattice. Such an analysis leads to the fact that the average drift velocity of electrons is twice as large. Taking this correction into account, the expression for the specific conductivity takes the following form:

$$\sigma = \frac{e^2 n \bar{v}}{m_o \bar{u}} . \quad (2.3)$$

The concept of free electrons makes it easy to arrive at the experimental Wiedemann-Franz law, which establishes the relationship between conductivity and thermal conductivity of a metal. Electrons in a metal not only carry an electric charge, but also equalize its temperature, providing high thermal conductivity. Due to the high concentration of free electrons, electronic thermal conductivity prevails over other heat transfer mechanisms. According to the atomic kinetic theory of an ideal gas, electronic thermal conductivity can be determined:

$$\lambda_T = \frac{1}{2} k n \bar{U} \bar{L}, \quad (2.4)$$

where k is the Boltzmann constant.

Dividing expression (2.4) by the specific conductivity found in (2.2), and taking into account that, according to the molecular kinetic theory, the average kinetic energy of electrons in a state of chaotic motion is determined by

$$\frac{m_o \bar{u}^2}{2} = \frac{3}{2} k T,$$

we will get

$$\frac{\lambda_T}{\sigma} = 3 k^2 e^{-2} T = L_o T . \quad (2.5)$$

That is, the ratio of the specific thermal conductivity to the specific conductivity of the metal at a given temperature is a constant value, independent of the nature of the conductor. From this, in particular, it follows that good conductors of electric current are also good conductors of heat. The constant $L_o = 3k^2/e^2$ was named the Lorentz number. A more rigorous analysis based on the quantum statistics of electrons gives a slightly different expression for the Lorentz number, although its numerical value does not change significantly:

$$L_o = \frac{\lambda_T}{\sigma T} = \frac{\pi^2}{3} \left(\frac{k}{e}\right)^2 = 2,45 \cdot 10^{-8} B^2 K^{-2} . \quad (2.6)$$

Experimental values of the Lorentz number at room temperature for the vast majority of metals agree well with the theoretical value.

However, in addition to the successful explanations of the experiment by the classical electronic theory of metals, contradictions also appeared. In particular, the classical theory could not explain the low heat capacity of the electron gas. The molar heat capacity of the crystal lattice of any solid body, which can be considered as a system of harmonically oscillating oscillators, is $3R$ (R is the universal gas constant). This result is known in physics as the Dulong-Pty law, which holds for solid bodies at a relatively high temperature.

In metals, atoms and free electrons must participate in the process of energy absorption. From this point of view, the heat capacity of the metal must be significantly greater than the heat capacity of dielectrics that do not contain free electrons. Assuming that the number of free electrons in a metal is equal to the number of atoms, and taking into account that electrons as particles of an ideal gas have an average thermal energy of $(3/2) kT$, for the molar heat capacity of metals we obtain

$$C_v = C_{lattice} + C_e = 3R + 3/2 kN_0 = 9/2R \quad . \quad (2.7)$$

However, in reality, the heat capacity of metals at high temperatures differs little from the heat capacity of crystalline dielectrics. This indicates that the electron gas practically does not absorb heat when heating a metal conductor, which contradicts the views of the classical electronic theory. The noted contradiction is the main one, but there are others. Difficulties in explanation were overcome with the help of the quantum theory of metals, the foundations of which were developed by the Soviet scientist Y. I. Frenkel and the German physicist A. Sommerfeld.

The main shortcomings of the classical theory come not so much from the ideas about the existence of free electrons in metals, but from the application to them of the laws of classical statistics (Maxwell-Boltzmann statistics), according to which the distribution of electrons by energy states is described by an exponential function of the form:

$$F(E) = A \exp \left[-\frac{E}{kT} \right] \quad (2.8)$$

In this case, any number of electrons can be in each energy state.

Quantum statistics is based on the Pauli principle, according to which only one electron can be in each energy state. This immediately leads to the difference between the classical and quantum distributions of electrons by energy. From the classical point of view, the energy of all electrons at a temperature of absolute zero must be zero. And according to Pauli's principle, even at absolute zero, the number of electrons at each level cannot exceed two. And if the total number of free electrons in a crystal is n , then at 0 K they will occupy 1/2 of the lowest energy levels.

In quantum theory, the probability of filling energy states with electrons is determined by the Fermi function:

$$F(E) = \left[1 + \exp \left(\frac{E - E_F}{kT} \right) \right]^{-1} \quad . \quad (2.9)$$

where E is the energy of the level whose occupancy probability is determined; E_F is the energy of the characteristic level with respect to which the probability curve is symmetric. At $T = 0$ K, the Fermi function has the following properties: $F(E) = 1$ if $E \leq E_F$, and $F(E) = 0$ if $E > E_F$.

Thus, the value of E_F determines the maximum energy that an electron can have in a metal at a temperature of absolute zero. This characteristic energy is called the Fermi energy or Fermi level. The potential corresponding to it $\varphi_F = E_F/e$ is called the electrochemical potential

From formula (2.9), it is easy to see that at any temperature, for a level with energy $E = E_F$, the probability of filling with electrons is 0.5. All levels below the

Fermi level are filled with electrons with a probability greater than 0.5. On the contrary, all levels above the Fermi level are free of electrons with a probability greater than 0.5.

The total electron concentration in a metal is found by integrating over all the filled states.

Systems of microparticles whose behavior is described by the Fermi-Dirac statistic can be in a degenerate state, which is characteristic of metals. In the degenerate state, the average energy of the electron gas is practically independent of temperature. The electron gas in a metal remains degenerate until any of the electrons can exchange energy with the crystal lattice, which, in turn, is possible only when the average energy of thermal vibrations becomes close to the Fermi energy. For metals, the degeneracy removal temperature is 10^4 K, which is higher than not only the melting point but also the vaporization temperature of metals.

As a result of degeneracy, not all free electrons can participate in the process of electrical conduction, but only a small fraction of them, which has an energy close to the Fermi energy. Only these electrons can change their states under the influence of a field. The electric current that occurs in a metal under the influence of a potential difference reflects changes in the distribution of electrons by velocity.

When the temperature changes, the Fermi energy changes little, which is a specific feature of the degenerate state of an electron gas. For example, when silver is heated from 0 to 1000 K, its Fermi energy decreases by only 0.2%. Such small changes in such a wide temperature range can be ignored. The concentrations of n free electrons in pure metals differ little. The temperature change of n is also very small. Therefore, the conductivity is determined mainly by the average free electron path length, which, in turn, depends on the structure of the conductor, i.e., the chemical nature of the atoms and the type of crystal lattice. The dependence of conductivity on temperature can also be explained by the wave-like nature of electron motion.

2.3 Temperature dependence of the electrical resistance of metals

It is known from physics that elementary particles have the property of particle-wave duality. Therefore, the movement of free electrons in a metal can be considered as the propagation of plane electron waves, the length of which is determined by the de Broglie relation:

$$\lambda = \frac{h}{m_0 u} = \frac{h}{\sqrt{2m_0 E}} . \quad (2.10)$$

Such a plane electron wave in a strictly periodic potential field propagates without energy dissipation. That is, the ideal lattice of a solid has no scattering effect on the electron flow. This means that in an ideal crystal, the free path length of electrons is equal to infinity, and the resistance to electric current is zero. This is confirmed by the fact that the resistance of pure metals tends to zero when the temperature approaches absolute zero. The property of an electron to move freely in an ideal crystal lattice has no analog in classical mechanics. Scattering and the appearance of resistance arise when there are various types of lattice disorders in the lattice.

In pure metals with a perfect structure, the only reason that limits the free path of electrons is the thermal oscillation of atoms in the lattice nodes. As the temperature increases, the amplitudes of thermal vibrations of atoms and the associated fluctuations

in the lattice periodic field increase. This, in turn, increases electron scattering and causes an increase in resistivity.

In the theory of lattice atomic vibrations, the temperature is evaluated relative to a certain characteristic temperature called the Debye temperature θ_D . The Debye temperature determines the maximum frequency of thermal vibrations that can be excited in a crystal:

$$\theta_D = h\nu_{max}/k \quad (2.11)$$

This temperature depends on the bonding forces between the nodes of the crystal lattice and is an important parameter of a solid.

To qualitatively determine the nature of the temperature dependence of resistivity, a somewhat simplified model of atomic vibrations and electron motion is used. The result is a formula that shows that the resistivity of metals at $T > \theta_D$ varies linearly with temperature:

$$\rho_T = \frac{1}{\sigma} = \frac{2\pi m_n^* k U_F}{e^2 k_{eb}} T = BT \quad (2.12)$$

where k_{eb} is the coefficient of elastic bonding that tends to return the atom to the equilibrium position, U_F is the thermal velocity of electrons with energy close to E_F .

As the experiment shows, the linear approximation of the temperature dependence of $\rho_T(T)$ is valid up to temperatures of the order of $(2/3)\theta_D$, where the error does not exceed 10%. For most metals, the characteristic Debye temperature does not exceed 400-450 K. Therefore, the linear approximation is usually valid at temperatures from room temperature and above. In the low-temperature region ($T < \theta_D$), where the resistivity decrease is due to the gradual exclusion of new frequencies of thermal vibrations (phonons), the theory predicts a power law dependence $\rho_l \sim T^5$. In physics, this relationship is known as the Bloch-Grüneisen law. The temperature interval in which a sharp power law dependence of $\rho_l(T)$ is observed is usually quite small, with experimental values of the power law ranging from 4 to 6.

The variation of the resistivity of a metal conductor with temperature is shown in fig. 2.1. At low temperatures, a number of metals can reach the state of superconductivity and the figure shows a jump in resistivity at the temperature T_{sc} .

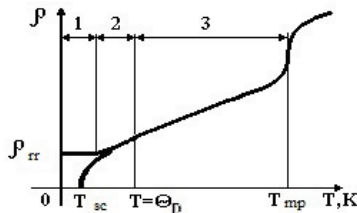

Fig. 2.1. Dependence of the resistivity of a metal conductor on temperature. T_{sc} - temperature of transition to the superconducting state, T_{mp} - melting point, ρ_{rr} - residual resistivity before transition to superconductivity

The relative change in resistivity when the temperature changes by one kelvin (degree) is called the temperature coefficient of resistivity:

$$\alpha_{\rho} = \frac{1}{\rho} \frac{d\rho}{dT} \quad (2.13)$$

The positive sign corresponds to the case when the specific resistance in the vicinity of this point increases with increasing temperature. The value of α_{ρ} can also depend on temperature. In the region of linear dependence $\rho(T)$, the expression is valid:

$$\rho = \rho_0 [1 + \alpha_{\rho} (T - T_0)] \quad (2.14)$$

where ρ_0 and α_{ρ} are the specific resistance and the temperature coefficient of the specific resistance, referred to the beginning of the temperature range, i.e. temperature T_0 , ρ - the specific resistance at temperature T . As a rule, T_0 is taken as 273 °K (0 °C).

2.4. Thin metal films. Dimensional effects

Metal films are widely used in microelectronics as contact pads, interconnects, capacitor linings, magnetic and resistive elements of integrated circuits. The electrical properties of thin films of metals and alloys can differ significantly from those of bulk initial conductive materials. One of the reasons for this difference is the variety of structural characteristics of thin films obtained, for example, by condensing molecular beams in a high vacuum. By varying the condensation conditions, the structure of the resulting films can vary from an extremely disordered fine state (amorphous state) to the structure of a perfect single crystal layer (epitaxial films). Another reason for the change in material properties in the film state is related to the manifestation of dimensional effects, i.e., the increasing role of surface processes compared to bulk processes. In particular, in electrical conductivity, the size effect occurs when the film thickness is commensurate with the average free path length of electrons. Under these conditions, the assumption that the resistivity of the material is independent of the geometric dimensions of the sample becomes unfair.

The structure of the films undergoes significant changes at different stages of their condensation, and this also affects the resistivity.

Thin films at the early stages of condensation have an island structure, i.e., with a small amount of deposited metal, its particles are located on the dielectric substrate in the form of separate scattered grains - islands. The electrical conductivity of the film occurs at a certain minimum amount of deposited metal. When an electric field is applied, electrons transfer through the narrow dielectric gaps between neighboring islands. The mechanisms responsible for the charge transfer are thermoelectron emission and tunneling; in particular, electrons located above the Fermi level can tunnel. The transition of electrons is facilitated by increasing temperature. In addition, the resistance of an island structure film is largely determined by the surface resistance of the areas of the substrate where there are no metal grains.

As the amount of deposited metal layer increases, the size of the gaps between the islands decreases, and the conductivity of the films increases. In the process of further condensation of the substance on the substrate, the islands merge and form conductive chains, and then a continuous homogeneous layer. However, even in a continuous film, the resistivity is higher than the resistivity of the original conductor, which is a consequence of the high concentration of defects - vacancies, dislocations, grain boundaries formed during the fusion of islands. Impurities absorbed from the residual gases have a major impact on the properties of films.

The resistivity of the film is also increased by the dimensional effect, i.e., the reduction of the free path length of electrons due to their reflection from the sample surface.

At room temperature, surface scattering of electrons occurs in pure metal films if their thickness is less than 200-300 Å. However, at low temperatures, when the free path length of electrons in the material volume increases significantly, the influence of dimensional effects is manifested at much greater film thicknesses.

Since the nature of the nucleation and growth of films depends on many random factors, it is difficult to obtain an exact match of resistivity values for films of the same thickness δ in practice. Therefore, for a comparative assessment of the properties of thin films, the resistivity of the square R_{\square} (resistivity of the surface) is used, which is numerically equal to the resistance of a film section whose length is equal to its width when the current passes through its two opposite faces parallel to the substrate surface:

$$R_{\square} = \frac{\rho_0}{\delta} \quad (2.15)$$

Given that R_{\square} does not depend on the size of the square, the resistance of a thin-film resistor can be easily calculated using the formula:

$$R = R_{\square} \frac{l_0}{d_0} \quad (2.16)$$

where l_0 is the length of the resistor in the direction of current flow; d_0 is the width of the film.

For the manufacture of thin-film resistors, films with a surface resistance of 500-1000 ohms/square are usually used. The most commonly used resistive materials are tungsten, molybdenum, tantalum, rhenium, chromium, and nickel-chromium alloy. Film resistors made of pure metals have the advantage that they are constant in composition and therefore it is easier to ensure the uniformity of their structure. This, in turn, leads to increased stability of electrical parameters.

2.5. Contact phenomena. Thermo EMF

When two different metals come into contact, a contact potential difference arises between them. This phenomenon was discovered by the Italian physicist A. Volta in 1797. According to quantum theory, the main reason for the potential difference at the contact is the different Fermi energy of the metals being contacted.

Let us assume that the electron gas in metals A and B (fig. 2.2) is characterized by Fermi energies E_F^A and E_F^B . Suppose $E_F^A < E_F^B$. The thermodynamic work of electron yield is equal to A_A and A_B , respectively. The kinetic energy of electrons at the Fermi level is different in different metals. Therefore, when materials come into contact, an intense transition of electrons occurs from a region with a large value of the Fermi energy to a region where this energy is lower, i.e. from metal B to metal A. Indeed, electrons tend to occupy a state with minimal energy. In fact, the transition of electrons from metal B to metal A is the transition of electrons in this system to lower energy levels. As a result of this process, metal B is positively charged and metal A is negatively charged; a potential difference arises between them, which prevents further transfer of charge carriers. Equilibrium will occur when the work of the electron to

overcome the forces of the created field becomes equal to the energy difference of the electrons passing through the contact:

$$eU_{\text{c}} = E_F^{\text{B}} = E_F^{\text{A}}$$

Thus, the internal contact potential difference is defined as the difference in Fermi energies, which are calculated from the bottom of the conduction band, for isolated metals A and B.

The presence of a contact field ensures the equality of electron fluxes from one metal to the other in the equilibrium state. Under conditions of steady-state equilibrium, the Fermi level in both metals should be the same: the energy levels in the positively charged metal will drop. Due to the charge of the regions, the level equalization can occur during the transition of a small number of electrons. The double electric layer d existing in the contact area is very thin (of the order of the lattice period) and does not affect the passage of electric current through the contact. Since the Fermi energy in metals has a value of about a few electron volts, the contact potential difference between two metals can range from tenths to several volts.

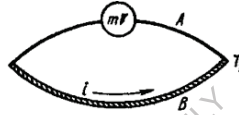

Fig. 2.2 Thermocouple circuit diagram

A thermocouple, consisting of two different conductors that form a closed circuit, is called a thermocouple (figure 2.2). When the temperature of the contacts in the closed circuit is different, a current called thermoelectric flows. If the circuit is broken at an arbitrary point, a potential difference will appear at the ends of the open circuit, which is called the thermoelectromotive force (thermo EMF). This phenomenon is called the Seebeck effect after its discoverer. As the experiment shows, in a relatively small temperature range, the thermoelectromotive force is proportional to the temperature difference between the contacts (junctions):

$$U = \alpha_T(T_2 - T_1). \quad (2.17)$$

Here, the proportionality coefficient α_T is called the relative differential or specific thermal EMF. The value of α_T depends on the nature of the contacting conductors and the temperature. The thermal EMF in the circuit consists of three components. The first of them is caused by the temperature dependence of the contact potential difference.

The second component of the thermo-EMF is caused by the diffusion of charge carriers from hot junctions to cold ones. They diffuse in greater numbers in the direction of the temperature gradient. The diffusion flow, carrying the negative charge from the hot end to the cold end, creates a potential difference between them.

The third component of the thermo-EMF occurs in the circuit due to the capture of electrons by thermal energy quanta (phonons). Their flow also extends to the cold end. All components of the thermo-EMF are determined by a small concentration of electrons located at energy levels close to the Fermi level and distant from it by a value of the order of kT . Therefore, the specific thermo-EMF for metals is very small.

Quantum theory gives the following expression for the specific thermal EMF of monovalent metals:

$$\alpha_T = \pi^2 \frac{k}{e} \frac{kT}{E_F} \quad (2.18)$$

At room temperature, α_T should be a few $\mu\text{V/K}$. A significantly higher value of the specific thermal EMF can be obtained when using metal alloys with a complex band structure.

Metal thermocouples are widely used for temperature measurement. During the measurement process, the temperature of one of the junctions is stabilized. Standard calibration tables are used for this purpose. For example, such a table for a chromel-kopel (Type L) thermocouple is shown in Appendix 2.

It should be noted that even in a homogeneous conductor, in the presence of a temperature gradient at its ends, a potential difference also arises due to the reasons discussed above. Its value, referred to a unit temperature difference at the ends of the conductor, is called the absolute specific thermal EMF. It can be proved that in a thermocouple circuit, the relative specific thermal EMF is equal to the difference of the absolute specific thermal EMF of the constituent conductors:

$$\alpha_T = \alpha_T^A - \alpha_T^B \quad , \quad (2.19)$$

where α_T^A and α_T^B are the absolute specific thermal EMF of the contacting metals A and B.

It follows from equation (2.19) that if the absolute value of the specific thermal EMF of one material, taken as a reference, is known, then for any other material this parameter can be obtained by measuring (calculating) it relative to this reference.

To determine the absolute thermoelectric EMF, lead is most often used as a reference, since its thermoelectric properties are very weak. At low temperatures, superconductors are used as standards, since the latter always have an absolute specific thermo-EMF of zero. The sign of the thermoelectric EMF is considered negative if the hot end of the conductor is positively charged, which is typical for most simple metals. In general, the absolute thermal EMF is highly temperature-dependent and can even change sign during heating.

2.6. Materials with high conductivity

This group of materials includes conductors with a resistivity under normal conditions of no more than $0.1 \mu\Omega \cdot \text{m}$. The most common among these materials are copper and aluminum.

The advantages of copper, which ensure its widespread use as a conductive material, are its low resistivity, fairly high mechanical strength, and satisfactory corrosion resistance in most cases (even in high humidity conditions, copper oxidizes in air much more slowly than, for example, iron. Intensive oxidation of copper occurs only at elevated temperatures (see fig. 2.3), good machinability (copper is rolled into sheets, strips and drawn into wire, the thickness of which can be brought to thousandths of a millimeter), relative ease of soldering and welding.

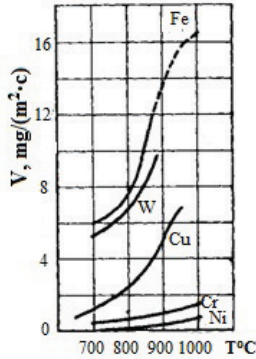

Fig. 2.3. Dependence of the oxidation rate V in air on the temperature T for iron Fe, tungsten W, copper Cu, chromium Cr, nickel Ni.

Copper is produced by processing sulphide ores, which are the most commonly found in nature. After a series of ore melts and intensive blast firings, copper intended for electrical purposes must be subjected to electrolytic purification. The copper cathode plates obtained after electrolysis are melted down into 80-90 kg ingots, which are rolled into products of the required cross-section.

The cold drawing method produces hard (hard-drawn) copper, which, due to the effect of riveting, has a high tensile strength and low relative elongation, as well as hardness and elasticity in bending; hard copper wire is slightly springy.

If copper is annealed, i.e. heated to several hundred degrees and then cooled, soft copper is obtained, which is relatively ductile, has low hardness and low strength, but very high relative elongation at break and higher specific conductivity. Copper is annealed in special furnaces without air to avoid oxidation. Standard copper at 20°C has a specific conductivity of $58.14 (\text{M}\Omega\cdot\text{m})^{-1}$, i.e. $\rho = 0.017241 \mu\Omega\cdot\text{m}$.

Oxygen-free copper is used in electric vacuum technology. It is obtained from electrolytic copper melted in a protective atmosphere of reductive CO gas. Oxygen released when copper is heated reacts with carbon monoxide and is removed as carbon dioxide. The best oxygen-free copper contains 99.97% Cu. An even purer metal is vacuum copper, smelted in vacuum induction furnaces in graphite crucibles at a residual gas pressure of about 10^{-3} Pa. It can contain 99.99% Cu. Oxygen-free copper has little difference in mechanical strength and electrical conductivity from conventionally smelted electrolytic copper. Its significant advantage is its high ductility.

The specific conductivity of copper is very sensitive to the presence of impurities. For example, if copper contains 0.5% of Zn, Cd or Ag impurities, its specific conductivity decreases by 5%. With the same content of Ni, Sn or Al, the specific conductivity of copper drops by 25-40%. At the same time, additives of many metals increase the mechanical strength and hardness of copper in both cold-drawn and annealed states.

The disadvantage of copper is its susceptibility to atmospheric corrosion with the formation of oxide and sulfide films. The oxidation rate increases rapidly with heating (see fig. 2.3), but the adhesion strength of the oxide film to the metal is low. As a result of oxidation, copper is unsuitable for low-current contacts. At high temperatures in an electric arc, copper oxide dissociates, exposing the metal surface. Metal delamination and thermal decomposition of the oxide film causes increased wear of copper contacts at high currents.

Hydrogen has a significant impact on the mechanical properties of copper. After hydrogen annealing, the hardness of copper can decrease several times. The destructive effect of hydrogen is especially pronounced in the presence of oxygen, which is present in industrial copper in the form of Cu_2O . Hydrogen easily penetrates deep into the metal at elevated temperatures and reacts.

Copper is used in electrical engineering to make wires, cables, switchgear busbars, transformer windings, electrical machines, conductive parts of devices and apparatus, and anodes in electroplating and galvanic plating. Copper strips are used as cable shields. Solid copper is used in cases where it is necessary to ensure particularly high mechanical strength, hardness and abrasion resistance, for example, for the manufacture of non-insulated wires. If good flexibility and ductility are required, and the tensile strength is not essential, then soft copper is more suitable. Special electrovacuum copper grades are used to make parts of klystrons, magnetrons, anodes of powerful generator lamps, power outputs of microwave devices, and some types of waveguides and resonators. In addition, copper is used to make foil getinax and is used in microelectronics in the form of films deposited on substrates that act as interconnects between functional circuit elements.

The second most important conductive material is aluminum, a silver-white metal, the most important of the so-called light metals. The resistivity of aluminum is 1.6 times higher than that of copper, but aluminum is 3.5 times lighter than copper. Due to its low density, it provides a high conductivity per unit mass, i.e., with the same resistance and the same length, aluminum wires are twice as light as copper wires, despite the larger cross-section. In addition, compared to copper, aluminum is much more common in nature and is characterized by lower cost. These factors contribute to the widespread use of aluminum in electrical engineering.

The disadvantage of aluminum is its low mechanical strength. Annealed aluminum is three times less tensile than annealed copper.

Aluminum is produced by electrolysis of alumina Al_2O_3 in a melt of cryolite Na_3AlF_6 at a temperature of 950°C .

For electrical purposes, aluminum of technical purity AE is used, containing no more than 0.5% of impurities. Wire made of aluminum and annealed at $350 \pm 20^\circ\text{C}$ has a resistivity at 20°C of no more than $0.0280 \mu\Omega\cdot\text{m}$. High-purity aluminum A97 (no more than 0.03% impurities) is used to make aluminum foil, electrodes and electrolytic capacitor housings. High-purity aluminum A999 has impurities not exceeding 0.001%. Its purity is controlled by the value of residual resistivity at liquid helium temperature, which should not exceed $4 \cdot 10^{-6} \mu\Omega\cdot\text{m}$

Different impurities reduce the specific conductivity of aluminum to varying degrees. Additions of impurities such as nickel, silicon, zinc, iron, arsenic, antimony,

lead and bismuth in the amount of 0.5% reduce the specific conductivity of aluminum by no more than 2-3%. Copper, silver, and magnesium impurities have a more noticeable effect, reducing it by 5-10% at the same weight content. Vanadium, titanium, and manganese additives also significantly reduce the specific conductivity of aluminum. The main impurities in technical aluminum are silicon and iron.

Aluminum is rolled, drawn and annealed in the same way as copper. Rolling aluminum can be used to produce very thin (6-7 microns) foil used as a lining in paper capacitors or plates of variable-capacitance capacitors.

The dependence of some physical properties of aluminum on temperature is shown in fig. 2.4. It is interesting to note that at the temperature of liquid nitrogen, aluminum is almost comparable to copper in terms of resistivity, and at even lower temperatures it becomes even better than copper. Therefore, the use of aluminum as a cryoconductor is promising.

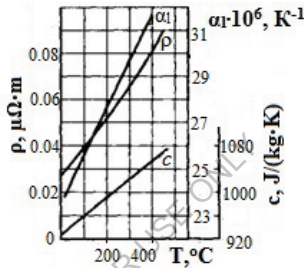

Fig. 2.4. Temperature dependences of resistivity ρ , specific heat capacity c , and temperature coefficient of linear expansion α_1 for aluminum

Aluminum is actively oxidized and covered with a thin film of oxide with high electrical resistance. Such a film protects aluminum from corrosion, but creates a high transient resistance at the points of contact of aluminum wires, which makes it impossible to braze aluminum using conventional methods. Therefore, special solder pastes are used to braze aluminum or ultrasonic soldering irons are used. A thicker oxide layer, which creates reliable electrical insulation for relatively high voltages, is obtained by electrochemical treatment of aluminum.

Oxide insulation is mechanically strong and heat-resistant. It can be relatively thin (a 0.03 mm thick oxide layer has a breakdown voltage of about 100 V, and a 0.04 mm thick layer has a breakdown voltage of about 250 V).

Various coils are made of oxidized aluminum. The disadvantages of oxide wire insulation are its limited flexibility (especially when the oxide layer is thick) and noticeable hygroscopicity (in cases where high heat resistance of oxide insulation is not required, it is varnished).

Oxide insulation is most widely used in electrolytic capacitors. It is also used in some types of rectifiers and arresters.

In practice, it is important to protect against galvanic corrosion in the areas of contact between aluminum and copper. If the contact area is exposed to moisture, a local galvanic couple with a sufficiently high emf value is formed, and the polarity of

this couple is such that the current is directed from aluminum to copper on the outer surface of the contact, as a result of which the aluminum conductor can be severely damaged by corrosion. Therefore, the junctions between copper and aluminum conductors must be carefully protected from moisture (varnished, etc.).

Aluminum films are widely used in integrated circuits as contacts and conductive connections. Films are usually deposited on silicon wafers by evaporation and condensation in a vacuum. The required pattern of connections is created using photolithography. The advantages of aluminum as a contact material are that it is easy to spray, has good adhesion to silicon, and provides good resolution in photolithography. In addition, aluminum forms good ohmic contacts with silicon.

The disadvantage of aluminum is its significant tendency to electromigration, which leads to an increase in resistance or even breakage of connections.

2.7. Superconductors

The phenomenon of superconductivity. Many metals and alloys exhibit a sharp decrease in resistivity at temperatures close to absolute zero. This phenomenon is called superconductivity, and the temperature T_{sc} at which the transition to the superconducting state occurs is called the critical transition temperature. Superconductivity was first discovered in mercury ($T_{sc} = 4.2$ K) by the Dutch physicist X. Kammerling-Onnes.

If an electric current is induced in a superconductor ring, it will not decay for a long time. The rate of decrease of the magnetic field of the induced current in the ring was used to estimate the resistivity of materials in the superconducting state. Its value was about 10^{-25} Ohm·m, which is 10^{17} times less than the resistance of copper at room temperature.

The phenomenon of superconductivity can only be understood and substantiated with the help of quantum representations. For almost half a century since its discovery, the essence of this phenomenon remained unsolved because the methods of quantum mechanics have not yet been fully used in solid-state physics. The microscopic theory of superconductivity was proposed in 1957 by the American scientists Bardeen, Cooper, and Schrieffer (BCS theory). The Soviet scientist N. N. Bogolyubov made a significant contribution to the development of the theory of superconductivity.

The phenomenon of superconductivity occurs when electrons in a metal are attracted to each other. The attraction of electrons is possible only in an environment containing positively charged ions, whose field weakens the Coulomb repulsion forces between electrons. Only those electrons that participate in electrical conduction, i.e., those located near the Fermi level, can be attracted. If such attraction occurs, then electrons with opposite directions of momentum and spin are bound into pairs, which are called Cooper pairs. In the formation of Cooper pairs, the interaction of electrons with thermal vibrations of the lattice - phonons - plays a crucial role. In a solid, electrons can both absorb and generate phonons. The exchange phonon interaction causes attractive forces between electrons that exceed the Coulomb repulsive forces. The exchange of phonons involving the lattice is continuous.

Since the attractive forces are small, the paired electrons are poorly localized in space. The effective diameter of a Cooper pair is of the order of 10^{-7} m, i.e., it covers

thousands of elementary cells. These pair formations overlap each other, constantly disintegrate and re-form, but in general, all pairs form an electron condensate whose energy is lower than that of a set of disconnected normal electrons due to internal interaction. As a result, an energy gap 2Δ appears in the energy spectrum of the superconductor, a region of forbidden energy states. The paired electrons are located at the bottom of the energy gap. The size of the energy gap depends on the temperature, reaching a maximum value at absolute zero and completely disappearing at $T = T_{sc}$. The BCS theory gives the following relation between the band gap width and the critical transition temperature

$$2\Delta = 3,52kT_{sc} \quad (2.20)$$

The formula (2.20) is well confirmed experimentally. For most superconductors, the energy gap is 10^{-4} - 10^{-3} eV.

As it has been shown, the electrical resistance of a metal is due to the scattering of electrons on thermal vibrations of the lattice and on impurities. However, in the presence of an energy gap, the transition of electrons from the ground state to the excited state requires a sufficient portion of thermal energy, which at low temperatures electrons cannot receive from the lattice, since the energy of thermal vibrations is less than the width of the gap. That is why the paired electrons do not scatter on defects in the structure. The peculiarity of Cooper pairs is their momentum ordering, which means that all pairs have the same momentum and cannot change their states independently of each other. The electron waves describing the motion of the pairs have the same length and phase. In fact, the motion of all electron pairs can be considered as the propagation of a single electron wave that is not scattered by the lattice and "flows around" the defects in the structure. Such consistency in the behavior of pairs is due to the high mobility of the electron condensate: sets of pairs are continuously changing, and there is a constant change of partners.

At absolute zero, all electrons located near the Fermi level are bound in pairs. As the temperature rises due to thermal energy, some of the electron pairs are broken, resulting in a decrease in the band gap width. The movement of unpaired electrons moving from the ground to the excited levels is hampered by scattering on lattice defects. At a temperature of $T = T_{sc}$, all pairs are completely broken, the band gap becomes zero, and superconductivity disappears.

The most important feature of superconductors is that the external magnetic field does not penetrate the thickness of the sample at all, damping in the thinnest layer. The magnetic field lines bend around the superconductor. This phenomenon, called the Meissner effect, is due to the fact that a circular, non-damped current arises in the surface layer of the superconductor when it is introduced to a magnetic field, which completely compensates for the external field in the thickness of the sample. The depth to which the magnetic field penetrates is usually 10^{-7} - 10^{-8} m. Thus, in terms of magnetic properties, superconductors are ideal diamagnets with a magnetic permeability of $\mu = 0$. Like any diamagnetics, superconductors are pushed out of the magnetic field. In this case, the effect of ejection is so strong that it is possible to hold a load in space with the help of a magnetic field. In a similar way, a permanent magnet can be made to hang above a ring of superconducting material, in which magnetically induced, non-damped currents circulate.

The superconducting state can be destroyed if the magnetic field strength exceeds a certain critical value, H_{sc} . According to the nature of the transition of the material from the superconducting state to the state of ordinary electrical conductivity under the influence of a magnetic field, superconductors of the I and II kind are distinguished. In superconductors of the first kind, this transition occurs abruptly as soon as the field strength reaches a critical value. Superconductors of the second kind gradually pass from one state to another; for them, there are lower H_{sc} and upper H_{sc2} critical field strengths. In the interval between them, the material is in an intermediate heterogeneous state in which normal and superconducting phases coexist. The ratio between their volumes depends on H . Thus, the magnetic field gradually penetrates the superconductor of the second kind. However, the material retains zero resistance up to the upper critical field strength.

The critical magnetic field strength depends on temperature. At $T = T_{sc}$, it turns to zero, but increases monotonically as the temperature tends to 0 K. For type I superconductors, the temperature dependence of H_{sc} is described to a good approximation by the expression:

$$H_{sc}(T) = H_{sc}(0)[1-(T/T_{sc})^2] \quad (2.21)$$

where $H_{sc}(0)$ is the critical field strength at absolute zero temperature.

The critical magnetic field strength for type I superconductors is approximately 10^5 A/m, and for type II superconductors the value of the upper critical strength can exceed 10^7 A/m

Superconductivity can be destroyed not only by an external magnetic field, but also by the current flowing through the superconductor, if it exceeds a certain critical value of I_{sc} . For type I superconductors, the limiting current density is limited by the critical magnetic field strength reached on the surface of the sample. In the case of a long straight wire of circular cross-section with radius r , the limiting current is determined by the formula:

$$I_{sc} = 2\pi r H_{sc}(T) \quad (2.22)$$

Since in superconducting elements the current flows in a thin surface layer, the average current density, referred to the entire cross-section, decreases with increasing wire diameter. For superconductors of the second kind, the relation (2.22) is not fulfilled, and the relationship between I_{sc} and N_{sc} is more complex.

The phenomenon of superconductivity at cryogenic temperatures is quite widespread in nature. There are 26 metals with superconductivity. Most of them are superconductors of the first kind with critical transition temperatures below 4.2 K. This is one of the reasons why most superconducting metals cannot be used for electrical purposes. Another 13 elements exhibit superconducting properties at high pressures. Among them are semiconductors such as silicon, germanium, selenium, tellurium, antimony, etc. It should be noted that the metals that are the best conductors under normal conditions do not have superconductivity. These include gold, copper, and silver. The low resistance of these materials indicates a weak interaction of electrons with the lattice. This weak interaction does not create sufficient electron attraction near

absolute zero to overcome the Coulomb repulsion. Therefore, their transition to the superconducting state does not occur.

In addition to pure metals, many intermetallic compounds and alloys have superconductivity. The total number of currently known superconductors is about 2000. Among them, alloys and compounds of niobium have the highest critical parameters (Table 2.1). Some of them make it possible to use a cheaper refrigerant, liquid hydrogen, instead of liquid helium, to achieve the superconducting state. Recently, superconducting materials with $T_{sc} > 77$ K have been discovered (see below).

Table 2.1. Basic properties of some superconducting alloys

Material	T_{sc} , K	Features
V ₃ Ga	14,8	Satisfactory mechanical properties
V ₃ Si	17,0	Same
Ni ₃ Sn	18,3	High current density, manufacturability
Nb ₃ Ga	20,3	High transition temperature, manufacturability
Nb ₃ Ge	21-24,3	The highest transition temperature

All intermetallic compounds and alloys are classified as superconductors of type II. However, the division of substances into two types based on their superconducting properties is not absolute. Any type I superconductor can be transformed into a type II superconductor by creating a sufficient concentration of lattice defects in the crystal. Superconductivity is never observed in systems with ferro- or antiferromagnetism. The formation of a superconducting state in semiconductors and dielectrics is prevented by the low concentration of free electrons. However, in materials with a high dielectric constant, the Coulombic repulsion forces between electrons are significantly weakened. Therefore, some of them also exhibit superconducting properties at low temperatures. An example is strontium titanate (SrTiO₃), which belongs to the group of ferroelectrics. A number of semiconductors can be transformed into a superconducting state by adding a large concentration of alloying impurities (GeTe, SnTe, CuS, etc.).

Today, the industry produces a wide range of superconducting wires and tapes for a variety of purposes. The manufacture of such conductors is associated with great technological difficulties. These are due to the poor mechanical properties of many superconductors, their low thermal conductivity and the complex structure of the wires. Intermetallic joints with high critical parameters are particularly fragile. Therefore, instead of simple wires and tapes, it is necessary to create compositions of two (usually a superconductor with copper) or even several metals. To produce stranded wires from brittle intermetallics, the so-called bronze method, which has been mastered by industry, is particularly promising. This method uses pressing and drawing to create a composition of thin niobium filaments in a tin-bronze matrix. When heated, the tin diffuses into the niobium, forming a thin superconducting film on its surface. Such a harness can be bent, but the films remain intact.

Superconducting elements and devices are becoming increasingly widely used in a wide variety of fields of science and technology. Large-scale long-term programs for the industrial use of superconductivity have been developed.

One of the main applications of superconductors is related to the generation of superstrong magnetic fields. Superconducting solenoids make it possible to obtain homogeneous magnetic fields with a strength of more than 10^7 A/m in a fairly large area of space, while the limit of conventional electromagnets with iron cores is about 10^6 A/m. In addition, superconducting magnetic systems circulate a non-damped current, so no external power source is required. Strong magnetic fields are required for scientific research. Superconducting solenoids can significantly reduce the size and energy consumption of synchrotrons and other particle accelerators. The use of superconducting magnetic systems for plasma containment in controlled fusion reactors, in magnetohydrodynamic (MHD) heat-to-electricity converters, and as inductive energy storage devices to cover peak power on the scale of large power systems is promising. The development of electric machines with superconducting excitation windings is being widely developed. The creation of superconducting transformers designed for high power levels is economically justified. Much attention is paid in different countries to the development of superconducting AC and DC power lines. Prototypes of pulsed superconducting coils for powering plasma guns and pumping systems for solid-state lasers have been developed. Superconducting bulk resonators with superconducting properties are used in radio engineering. The principle of mechanical ejection of superconductors from a magnetic field is the basis for the creation of ultra-high-speed rail transport on a "magnetic cushion".

The use of superconductors opens up broad prospects for measuring technology. By complementing the capabilities of existing measuring instruments, superconducting elements make it possible to record very subtle physical effects, measure with high accuracy, and process large amounts of information.

Highly sensitive bolometers for recording infrared radiation, magnetometers for measuring weak magnetic fluxes, and indicators of ultra-low voltages and currents have already been created on the basis of superconductivity.

In 1986, Karl Müller and Georg Bednorz discovered the first compound from the class of high-temperature superconductors of cuprite $\text{La}_{2-x}\text{Ba}_x\text{CuO}_4$. They were awarded the Nobel Prize for this discovery in 1987. High-temperature superconductors are a family of materials (superconducting ceramics) with a common structural feature, relatively well-separated copper-oxygen planes. They are also called cuprite-based superconductors. The superconducting transition temperature that can be achieved in some compositions in this family is the highest of all known superconductors. At present, the record value of the critical temperature $T_c = 135$ K (under pressure $T_c = 165$ K) is held by the substance $\text{HgBa}_2\text{Ca}_2\text{Cu}_3\text{O}_{8+x}$, discovered in 1993. S. N. Putilin and E. V. Antipov of Moscow State University. The normal (and superconducting) states show many common features between different compositions of cuprates. Many of these properties cannot be explained within the framework of the BKS theory. There is currently no consistent theory of superconductivity in cuprates. Nevertheless, the problem has led to many experimental and theoretical results.

2.8. Metals and alloys for various purposes. High resistance alloys.

High-resistance alloys are conductive materials whose ρ value under normal conditions is at least $0.3 \mu\Omega\cdot\text{m}$. They are used in the manufacture of electrical measuring instruments, reference resistors, rheostats, and electric heating devices. When alloys are used in electrical measurement equipment, they are required not only to have a high resistivity, but also to have a lower $\alpha\rho$ value as possible, as well as a low thermal energy coefficient of thermal expansion relative to copper. In electric heating devices, conductive materials must operate for a long time in air at temperatures of about 1000°C . Among a large number of materials for these purposes, the most common in practice are copper-based alloys such as manganese and constantan, as well as chromium-nickel and iron-aluminum alloys.

Manganese is the main copper-based alloy for electrical measuring instruments and reference resistors. Manganese is characterized by a yellowish tint and is well drawn into thin wire up to a diameter of 0.02 mm . Manganese is also used to make ribbon with a thickness of $0.01\text{-}1 \text{ mm}$ and a width of $10\text{-}300 \text{ mm}$.

Constantane is an alloy of copper and nickel. The nickel content in the alloy approximately corresponds to the maximum ρ and minimum $\alpha\rho$ for Cu-Ni alloys. Constantane is easy to process; it can be drawn into wire and rolled into strip of the same dimensions as manganese. The $\alpha\rho$ value of constantan is close to zero and usually has a negative sign.

Constantane is used for the manufacture of rheostats and electric heating elements in cases where the operating temperature does not exceed $400\text{-}450^\circ\text{C}$.

When heated to a sufficiently high temperature, an oxide film is formed on the surface of the constantan, which has electrical insulating properties. Constantan wire coated with such insulation can be wound tightly, coil to coil, without much insulation between the coils, unless the voltage between adjacent coils exceeds 1 V . This is how rheostats are made, for example. The oxidation of a constantan wire, which produces a fairly flexible and durable oxide film, requires rapid (no more than 3 seconds) heating of the wire to a temperature of 900°C , followed by air cooling.

Constantane paired with copper or iron has a high thermal emf. This is a disadvantage when using constantan resistors in measuring circuits. Due to the temperature difference in the places of contact of constantan conductors with copper, thermal emfs occur, which can be a source of errors, especially in zero measurements in bridges and potentiometric circuits.

Constantane is successfully used to make thermocouples that measure temperature if the latter does not exceed several hundred degrees.

Chromium-nickel alloys (nichromes) are used to make heating elements for electric furnaces, tiles, soldering irons, etc. These alloys are used to make wires with a diameter of 0.02 mm and more, and tapes with a cross-section of $0.1 \times 1.0 \text{ mm}$ and more.

The high heat resistance of nichrome can be explained by the significant resistance of this alloy to progressive oxidation in air at high temperatures.

The resistance of chromium-nickel alloys at high temperatures in air is explained by the close values of the temperature coefficients of linear expansion of the alloys and their oxide films. Therefore, the latter do not crack or separate from the wire when it is

heated and expanded. However, although the temperature coefficients of expansion of the alloy and chromium and nickel oxides are close, they are not the same. As a result, the oxide layer may crack during sudden changes in temperature. During subsequent heating, oxygen penetrates the cracks and causes additional oxidation of the alloy. Consequently, with repeated short-term switching on, a chromium-nickel alloy electric heating element can burn out faster than in the case of continuous heating (the heating temperature is the same in both cases, and the service life can differ by a factor of 20-30).

The service life of the heating elements can be increased by embedding the spirals in a solid inert medium such as clay chamotte, which protects them from mechanical stress and impedes oxygen access.

Thin films of nichrome X20N80 produced by thermal evaporation and condensation in a vacuum are widely used to manufacture thin-film resistors, in particular, integrated circuit resistors. The chemical composition of the films can differ significantly from that of the original evaporated alloy, due to significant differences in the vapor pressure of nickel and chromium at evaporation temperatures. Therefore, the composition of the condensate depends on many technological factors: deposition rate, temperature and substrate material, residual vapor pressure in the chamber, etc.

Alloys for thermocouples. The vast majority of thermocouples are made of metal alloys. It should be noted that there are materials with much higher thermoelectric emf values. These materials primarily include semiconductors. However, the technology for manufacturing thermocouples from semiconductors is very complex and imperfect.

The following alloys are most commonly used to make thermocouples:

1) copel (56% Cu and 44% Ni); 2) alumel (95% Ni, the rest are Al, Si and Mn); 3) chromel (90% Ni and 10% Cr); 4) platinum (90% Pt and 10% Rh).

The dependences of thermo-EMF on the temperature difference between hot and cold junctions for different thermocouples are shown in Fig. 2.5.

A change, even a small one, in the alloy composition can lead to significant changes in the thermo-EMF values. In these cases, to achieve high measurement accuracy with thermocouples, preliminary calibration is required instead of using standard tables.

Upper temperature limits for thermocouples: platinum - platinum up to 1600°C; copper - constant and copper - copper up to 350°C; iron - constant, iron - copper and chromium - chromium up to 600°C; chromium - alumel up to 900-1000°C.

Of the known metal thermocouples, the chromel-copel thermocouple has the highest thermoelectric emf at the same temperature difference. The thermoelectric sign of the thermocouples shown in fig. 2.5 thermocouples is as follows: in the cold junction, the current is directed from the first material named in the pair to the second (from chromel to copel, from copper to constant, etc.), and in the hot junction - vice versa.

Most thermocouples operate stably in an oxidizing environment. During long-term operation, a gradual change in thermal emf can be observed. The reasons for this instability are contamination with impurities from the surrounding atmosphere, wire oxidation, component volatility, sharp bends and mechanical deformations that

introduce internal stress and create structural heterogeneity. Platinum-rhodium thermocouples have the highest stability, accuracy, and reproducibility, despite the low value of thermal emf. This is due to the chemical inertness of the material and the high degree of purity of the material obtained.

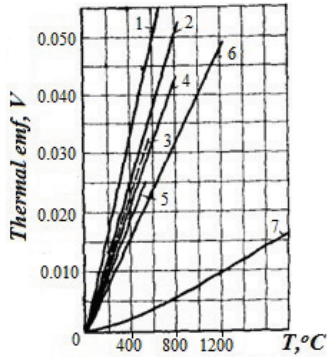

Fig. 2.5. Dependence of thermoEMF on the temperature difference of hot and cold junctions for thermocouples: 1 - chromel - copel, 2 - iron - copel, 3 - copper - copel, 4 - iron - constantan, 5 - copper - constantan, 6 - chromel - alumel, 7 - platinorhodium - platinum

Non-metallic materials that conduct current. Along with metals and metal alloys, various composite materials, some oxides and modifications of carbon are widely used as resistive, contact and conductive elements. As a rule, these materials have a highly specialized purpose.

Among solid non-metallic conductors, graphite, one of the allotropic forms of pure carbon, is the most widely used in electrical engineering. Along with its low resistivity, graphite's valuable properties include significant thermal conductivity, resistance to chemically aggressive environments, high heat resistance, and ease of machining. Natural graphite, anthracite, and pyrolytic carbon are used to produce electric carbon products.

Natural graphite is a large-crystalline material with a very high melting point (about 3900°C). Under free access to oxygen and high temperature, it oxidizes to form gaseous oxides C and CO₂.

Pyrolytic carbon is produced by thermal decomposition of hydrocarbon vapor in a vacuum or in an inert gas environment (pyrolysis). Methane compounds are usually chosen as substances to be pyrolyzed. To obtain a dense structure, a pyrolysis temperature of at least 900°C is required. Pyrolytic carbon films are widely used to produce surface-type linear resistors.

Carbon black is a fine form of carbon. It is obtained as a product of incomplete combustion or thermal decomposition of carbon-containing substances. When incorporated into a binder, carbon blacks tend to form structures.

The production of most carbon products involves grinding carbon raw materials into powder, mixing it with binders, molding and firing, after which the product has sufficient mechanical strength and hardness and can be machined.

Graphite is widely used in semiconductor materials technology to manufacture various types of heaters and screens, shuttles, crucibles, cassettes, etc. In vacuum or protective gas environments, graphite products can be operated at temperatures up to 2500°C.

A special modification of graphite is glassy carbon, which is obtained by polymerization of organic polymer resins such as bakelite, carried out in an atmosphere of neutral gases for a long time. The manufactured products have a shiny surface, a glassy appearance and a shell-like fracture. Glassy carbon differs from ordinary graphite in its increased chemical resistance.

There are composite materials that conduct current. Composite materials are a mechanical mixture of a conductive filler with a dielectric bond. By changing the composition and distribution of the components, the electrical properties of such materials can be controlled within a fairly wide range. A feature of all composite materials is the frequency dependence of conductivity and aging under prolonged loading. In some cases, the nonlinearity of electrical properties is noticeably pronounced. Metals, graphite, carbon black, some oxides and carbides are used as components of the conductive phase. Both organic and inorganic dielectrics can act as a binder.

Among the variety of combined conductive materials, the most noteworthy are contactors and cermets.

Contactants are used as conductive adhesives, paints, coatings and enamels. They are low-viscosity or paste-like polymer compositions. Various synthetic resins are used as binders, and fine metal powders (silver, nickel, palladium) are used as conductive fillers. The required viscosity of contactol is ensured by the use of solvents (acetone, alcohol, etc.) before applying them to the surface. Contact materials are used to make contacts between metals, metals and semiconductors, to create electrodes on dielectrics, to shield rooms and devices from interference, for conductive communications on dielectric substrates, in flexible waveguides and other electronic products.

Cermets are metal-dielectric compositions with an inorganic binder. They are used to make thin-film resistors. A significant advantage of cermet films is the ability to vary their resistivity over a wide range. The most widely used is the Cr-SiO microcomposition, whose thin films are made by thermal evaporation and condensation in a vacuum, followed by heat treatment to stabilize the properties.

Thick-film microcircuits use resistors made from a composition of glass with palladium and silver.

Materials based on conductive oxides. Tin dioxide is of the greatest practical interest. In radio electronics, it is used mainly in the form of thin films. Such films are produced by various methods: thermal vacuum evaporation and condensation followed by air annealing, cathodic or ion-plasma sputtering, etc. Oxide is characterized by very strong adhesion to ceramic or glass substrates. The adhesion strength reaches 20 MPa, which is much higher than that of metal films. The resistivity of the films depends on the degree of stoichiometric disturbance and can be as high as 10^{-5} Ohm·m. Heating of SnO₂ films above 240°C leads to an irreversible change in resistance as a result of more complete oxidation. At the same time, the films are resistant to many chemical

environments - they are destroyed only by hydrofluoric acid and boiling alkalis. Thin layers of tin dioxide have a valuable optical property - high transparency in the visible and infrared parts of the spectrum. The intrinsic absorption of SnO_2 films up to 2 microns thick in the visible part of the spectrum does not exceed 3%.

The combination of high optical transparency and increased electrical conductivity of tin dioxide films makes them suitable for use as conductive coatings on the inner walls of glass cylinders of electric vacuum devices, electrodes of electroluminescent capacitors and liquid crystal indicators, television transmission tubes, etc.

In addition to tin dioxide, films of indium oxide In_2O_3 have high electrical conductivity and transparency in the visible spectrum. They have similar applications.

Solders. Solders are special alloys used for brazing. Brazing is performed either to create a mechanically strong joint or to make electrical contact with a low transient resistance. During brazing, the joints and solder are heated. Since the solder has a melting point significantly lower than the metal to be joined, it melts, while the base metal remains solid. Various physical and chemical processes occur at the interface between the molten solder and the solid metal. The solder wets the metal, spreads over it and fills the gaps between the parts to be joined. At the same time, the solder components diffuse into the base metal, the base metal dissolves in the solder, resulting in the formation of an intermediate layer that, after solidification, joins the parts into a single whole.

Solders are usually divided into two groups: soft and hard. Soft solders are those with a melting point of up to 300°C , and hard solders are those above 300°C . In addition, solders differ significantly in mechanical strength. Soft solders have a tensile strength of 16-100 MPa, while hard solders have a tensile strength of 100-500 MPa.

The solder is selected taking into account the physical and chemical properties of the metals to be joined, the required mechanical strength of the joint, its corrosion resistance and cost. When soldering conductive parts, the specific conductivity of the solder must be taken into account.

Soft and hard solders are used in various fields of radio electronics.

Soft solders are tin-lead alloys with a tin content of 10 to 90%, the rest is lead. The conductivity of these solders is 9-15% of that of pure copper. A large number of tin-lead solders contain a small percentage of antimony.

The most common solid solders are copper-zinc and silver with various additives.

Auxiliary materials for reliable soldering are called fluxes. They must:

- 1) dissolve and remove oxides and contaminants from the surface of the metals to be soldered;
- 2) protect the surface and the molten solder from oxidation during the brazing process
- 3) reduce the surface tension of the molten solder;
- 4) improve solder wettability of the surfaces to be joined.

Fluxes are divided into several groups according to their effect on the metal to be soldered.

Active, or acid, fluxes are prepared on the basis of active substances such as hydrochloric acid, chloride and fluoride metals, etc. These fluxes intensively dissolve oxide films on the metal surface, which ensures good adhesion and, consequently, high mechanical strength of the joint. Residual flux after brazing causes intense corrosion of the joint and the base metal. Therefore, these fluxes are used only when thorough washing and complete removal of their residues is possible.

The use of active fluxes is strictly prohibited for assembly soldering of electrical and radio devices.

Acid-free fluxes are rosin and fluxes prepared on its basis with the addition of inactive substances (alcohol, glycerin).

Activated fluxes are prepared on the basis of rosin with the addition of activators - small amounts of hydrochloric acid or phosphoric acid aniline, salicylic acid, hydrochloric acid diethylamine, etc. The high activity of some activated fluxes allows soldering without preliminary removal of oxides after degreasing.

Anti-corrosion fluxes are produced on the basis of phosphoric acid with the addition of various organic compounds and solvents, as well as on the basis of organic acids. Flux residues do not cause corrosion.

2.9. Nanotechnology materials and nanotechnologies.

Nanomaterials are materials created with the use of nanoparticles using nanotechnology. Nanomaterials include objects with one of their characteristic dimensions in the range of 1 to 100 nm. There is a division of nanomaterials: nanoporous structures, nanoparticles, nanotubes and nanofibers, nanodispersions (colloids), nanocrystals and nanoclusters.

According to their purpose, nanomaterials are divided into functional, composite, and structural. By the number of dimensions: zero-dimensional, one-dimensional, two-dimensional, three-dimensional.

The properties of nanomaterials are usually different from similar materials in the massive state. For example, changes in magnetic, thermal, and electrical properties can be observed in nanomaterials. For particularly small materials, you may notice a change in the melting point towards a decrease.

Nanomaterials face the problem of storage and transportation. Having a developed surface, the materials are very active and readily interact with the environment, especially metal nanomaterials. The use of nanomaterials is not yet widely developed, as their detailed study has just begun and knowledge about these materials is still being accumulated.

The first elements of nanostructures were stable multi-atomic carbon clusters C_n discovered in 1960, where $n = 60, 70$ represents the number of carbon atoms in the most stable clusters. They were named fullerenes in honor of the American architect and inventor Richard Fuller, who proposed building structures in the form of hemispheres consisting of fragments of polyhedral surfaces. Fullerenes were first obtained by analyzing the products obtained as a result of laser radiation on graphite.

Unlike graphite and diamond, which have periodic lattices of atoms, fullerenes are molecules. The framework of the C_{60} molecule, for example, consists of 12 regular pentagons (pentagons) and 20 unequal hexagons (fig. 2.6).

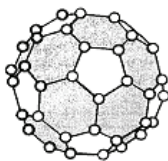

Fig. 2.6 Fullerene

It turned out that some cluster configurations are highly stable, and all the outer atoms in them are held very tightly. Such clusters are called magic clusters, and the numbers of atoms in them are called magic numbers. For example, for alkali metal atoms, the magic numbers are 8, 20, 40, and for noble metal atoms, 13, 55, 137, 255. C60, C70 and other fullerenes are also magic numbers.

Due to the variety of additives, the number of variants of fullerene materials, semiconductors with properties of metals, ferromagnets, and polymers is estimated in the thousands.

C60 molecules can form crystals of so-called fullerites with a lattice of FCC and rather weak intermolecular bonds. The interatomic cavities of fullerenes can be filled with impurity atoms (alkali metals, etc.). As it turned out, nanomaterials with different, often unique properties are obtained on the basis of fullerides doped with K, Rb, Cs, etc.

Therefore, fullerene and fulleride compounds can be considered building blocks of three-dimensional nanoblocks.

Fullerenes have been used in nanoelectronics as mechanically strong resistors with high resolution. The addition of fullerenes makes it possible to increase the resistance of resistors to plasma etching and reduce optical absorption at a wavelength of 0.193 microns. In 2000, nanotransistors based on C60 fullerene clusters were produced.

Nanotubes. Nanotubes are long structures consisting of coiled hexagonal grids with carbon atoms in the nodes. They were discovered in 1991 by Japanese researcher Sumio Iijima as by-products of the synthesis of fullerenes C40, C60, C70, etc. The scientist studied the precipitate formed on the cathode when graphite is sprayed in an electric arc in a vacuum or inert gas. The chains of deposited carbon atoms are curled into tubes with a diameter of several nm and a length of up to several microns. The ends of the tubes are closed by single- or multi-layer hemispherical molecules resembling fullerenes in structure. It was found that nanotubes are molecules containing more than 106 carbon atoms and have the form of single-walled tubes with a diameter of 1.1 nm and a length of several tens of micrometers. However, the length of carbon nanotubes is a thousand times or more than their diameter. In principle, this makes it possible to use the tubes as conductors for three-dimensional assembly of nanocircuits.

The structure of a single-walled carbon nanotube is a cylindrically rolled ribbon with a graphite-like packing of atoms. Carbon nanotubes are magical. This circumstance has led to the prospects of the technology of preliminary creation of

magical nanostructures in special reactors and their subsequent use in the assembly of nanotransistors.

Dependences of the electrical properties of nanotubes on geometric parameters were predicted on the basis of quantum chemical calculations of their band structure. Carbon nanotubes represent quantum conductors with quantum mechanical properties. In particular, the band gap for the electrons of a quantum conductor increases with the intensity of the applied transverse electric field. In this case, the band gap is inversely proportional to the diameter of the tube: $\Delta W_g \sim 1/d$. The design of a field-effect nanoelectronic transistor is based on these principles. These relationships were experimentally confirmed in 1998.

In 2004, a nanotransistor operating at a frequency of 2.6 GHz was created on the basis of a single-layer carbon nanotube with gold electrodes. In the same year, a record-small nanotransistor was created on the basis of smaller carbon nanotubes: the tube diameter is 0.7-1.1 nm with a channel length of 50 nm. The drain and source electrodes were made of palladium. The transistor also has a record high resistance ratio in the closed and open modes - about 10^6 .

Nanotubes have a number of unique properties. Single-walled nanotubes can be elongated by up to 16% of their length. Their high mechanical strength, which is a hundred times higher than that of steel, makes them suitable for use as probes in scanning tunneling microscopes. Nanotubes can be used to make ultra-strong and elastic fabrics. Nanotubes with open ends exhibit a capillary effect and are able to draw in liquids and molten metal. This makes it possible to produce superconducting filaments with a diameter of several nanometers on the basis of nanotubes. Metal nanotubes can withstand very high current densities (100-1000 times higher than conventional metals).

A specific property of nanotubes is chirality. Chirality is the angle of orientation of the graphite plane relative to the tube axis. Depending on the chirality, a single-layer tube can exhibit the properties of graphite, a semi-metal that does not have a band gap. The nanotube can also have the properties of a semiconductor with a band gap of 0.01-0.70 eV. Semiconductor nanotubes have the ability to switch to the insulator state under the influence of an external electric field.

If two nanotubes with different chirality are joined, a p-n junction can be created. The size of such a junction is several nanometers and opens up the possibility of assembling electronic devices.

An example of a model of the structure of an electronic component with rectifying properties is shown in fig. 2.7. The contact is obtained by joining two nanotubes with different chirality. The metal-semiconductor contact in such a diode structure can be obtained by selectively filling and doping the carbon nanotube with impurities that create metallic and semiconductor or dielectric types of conductivity.

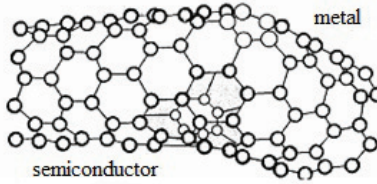

Fig. 2.7. Model of a curved carbon tube - diode

Nanotubes have high emissive characteristics. With a voltage of 500 V at room temperature, the autoelectronic emission gap reaches 0.1 A/cm^2 .

On the basis of carbon nanotubes, ultra-thin display panels are being developed, which in their parameters surpass those of rare crystals.

One of the features of carbon nanotubes is the high negative value of diamagnetic susceptibility. Diamagnetism increases at low temperatures.

The practical application of nanotubes leads to a solution to a number of problems. Technologies for the production of nanotubes are not sufficient enough, and that does not allow the production of nanotubes of a given diameter and length, a given chirality. For a practical use of nanotubes, it is necessary to supply power, connected with quantization of electric and magnetic fields. Identify and other problems.

FOR AUTHOR USE ONLY

Chapter 3. Semiconductor materials

3.1 Intrinsic and impurity semiconductors

The current in semiconductors is the movement of electrons and holes and contains drift and diffusion components. The drift component of the current is proportional to the concentration of carriers, and the diffusion component is proportional to the gradient of the spatial distribution of this concentration.

The statistical method of the energy distribution of carriers in a semiconductor leads to the following. The concentration of electrons in a semiconductor whose Fermi energy (level) lies in the forbidden zone and is more than kT below the bottom of the conduction band is determined by the following formula:

$$n = N_c \cdot \exp\left(-\frac{E_c - E_F}{kT}\right), \quad (3.1)$$

where N_c is the effective density of states in the conduction band, E_c is the energy at the bottom of the conduction band, and E_F is the Fermi energy.

Such semiconductors are called non-degenerate.

When the carrier concentration increases, the moment may come when $E_c < E_F$ and such semiconductors go into a state called degenerate. For them, the carrier concentration is determined by numerical calculations according to the formula:

$$n = N_c \frac{2}{\sqrt{\pi}} \cdot F_{1/2}\left(\frac{E_F - E_c}{kT}\right). \quad (3.2)$$

The function $F_{1/2}$ is the Fermi-Dirac integral, which is displayed in tabular form.

The following formulas are valid for the concentration of holes in the valence band:

- for a non-degenerate semiconductor :
$$p = N_v \cdot \exp\left(\frac{E_v - E_F}{kT}\right) \quad (3.3)$$

- for a degenerate semiconductor :
$$p = N_v \frac{2}{\sqrt{\pi}} F_{1/2}\left(\frac{E_v - E_F}{kT}\right) \quad (3.4)$$

The limiting concentration of holes in non-degenerate and degenerate p-type semiconductors is determined similarly to the electron concentration and is, for example, $3.75 \cdot 10^{18} \text{ cm}^{-3}$ for silicon.

Semiconductors that are free of impurities are called intrinsic. In intrinsic semiconductors, electrons located near the ceiling of the valence band are excited by thermal energy and can enter the conduction band, leaving holes in the valence band. Therefore, the concentrations of electrons in the conduction band and holes in the valence band are the same $n = p \equiv n$, where n is the intrinsic carrier concentration.

Suppose that impurities are added to the intrinsic semiconductor, for example, phosphorus (P) atoms (donors) are added to silicon. The ionization energy of phosphorus is small - 0.012 eV, so at room temperature all P atoms are ionized.

Accordingly, the electron concentration is equal to the P concentration. If the temperature is lowered, the impurities are only partially ionized and the electron concentration decreases. This phenomenon is called the carrier freezing effect. Similar processes occur when an acceptor impurity is added. When both donors and acceptors are introduced at room temperature, both types of impurities are ionized and the amount of carriers is determined as the difference between the donors and acceptors. This effect is called impurity compensation.

The temperature dependence of the electron concentration at the donor levels in an n -type semiconductor is determined:

$$n_d = N_d \left\{ 1 - \frac{1}{1 + \frac{1}{g} \exp\left(\frac{E_d - E_F}{kT}\right)} \right\}, \quad (3.5)$$

where N_d is the concentration of donors, E_d is the energy level of donors, $\Delta E_d = E_d - E_F$ is the ionization energy of donors, and g is the degeneracy factor, which is equal to 2, taking into account the electron spin.

A similar formula can be obtained for an acceptor semiconductor.

3.2. Temperature dependence of current carrier concentration and specific conductivity in semiconductors

In a wide range of temperatures and for different impurity contents, there are temperature dependences of the concentration of charge carriers in an n -type semiconductor, shown in Fig. 3.1. Consider the nature of the curves corresponding to a relatively low concentration of N_{D1} donors. In the low temperature region, the increase in electron concentration when the semiconductor is heated is due to an increase in the degree of donor ionization (the section of the curve between points 1 and 4).

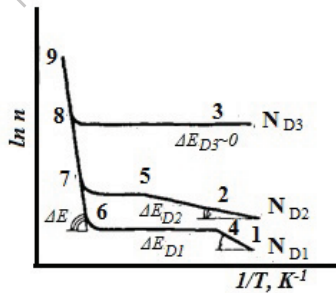

Fig. 3.1. Characteristic dependences of the concentration of charge carriers in a semiconductor on temperature at different concentrations of donor impurities $N_{D1} < N_{D2} < N_{D3}$

Each ionized donor can be considered as a center that has captured a hole. Considering that the total number of energy states at the donor levels per unit volume is equal to N_{D1} , for the concentration of ionized donors p_D we write

$$p_D = N_{D1} \exp\left(\frac{E_{D1} - E_F}{kT}\right), \quad (3.6)$$

where E_{D1} is the position of the donor level on the energy scale.

At low temperature, the concentration of ionized donors is equal to the concentration of electrons:

$$p_D = n_o = N_c \exp\left(-\frac{E_c - E_F}{kT}\right), \quad (3.7)$$

It follows that

$$p_D n_o = n_o^2 = N_c N_{D1} \exp\left(\frac{E_{D1} - E_F}{kT}\right) \exp\left(-\frac{E_c - E_F}{kT}\right), \quad (3.8)$$

and accordingly

$$n_o = \sqrt{N_c N_{D1}} \exp\left(-\frac{\Delta E_{D1}}{2kT}\right), \quad (3.9)$$

where $\Delta E_{D1} = E_c - E_{D1}$.

From expression (3.9), it follows that the slope of the line in the section 1-4 of fig. 3.1 characterizes the ionization energy of impurities. In the process of further heating at a certain temperature corresponding to point 4, all electrons from impurity levels are transferred to the conduction band. At the same time, the probability of ionization of the semiconductor's own atoms is still negligible. Therefore, in a fairly wide temperature range (region 4-6), the concentration of charge carriers remains constant and almost equal to the concentration of donors. This section of the temperature dependence is commonly referred to as the impurity depletion region.

At relatively high temperatures (curve section beyond point 6), electron transfer across the band gap begins to play a dominant role, i.e., the transition to intrinsic electrical conductivity occurs, where the electron concentration is equal to the hole concentration, and the curve steepness is determined by the band gap of the semiconductor.

For most impurity semiconductors, the temperature T_i of the transition to intrinsic electrical conductivity is significantly higher than room temperature. For example, for n -type germanium with a donor concentration of $N_D \sim 10^{22} \text{ m}^{-3}$, the T_i temperature is approximately 450 K. The value of T_i depends on the concentration of impurities and the width of the semiconductor band gap.

As the impurity concentration increases, the parts of the curves corresponding to the impurity electrical conductivity shift upward. The reason for this shift can be easily understood using formula (3.9). In addition, it should be taken into account that as the concentration of impurity atoms increases, the distance between them decreases. This leads to stronger interaction of the electron shells of impurity atoms and splitting of discrete energy levels into impurity zones. Accordingly, the ionization energy of impurities decreases. For this reason, $\Delta E_{D1} > \Delta E_{D2} > \Delta E_{D3}$. The higher the concentration of impurities, the higher the temperature of their depletion.

At a sufficiently high concentration of donors (N_{D3}), their ionization energy turns to zero, since the impurity band overlaps with the conduction band. Such a semiconductor becomes degenerate. In this case, the temperature dependence of the charge carrier concentration is characterized by a broken line with two straight segments 3-8 and 8-9. The concentration of electrons in a degenerate n -type semiconductor is constant over the entire range of impurity conductivity. A degenerate

semiconductor is capable of conducting electric current even at very low temperatures. These properties make degenerate semiconductors similar to metals. Therefore, they are sometimes called semimetals.

The Fermi level is one of the main parameters characterizing the electron gas in semiconductors. The position of the Fermi level in a non-degenerate semiconductor at low temperatures can be found by logarithmizing equation (3.7):

$$\ln p_D = \ln N_{D1} + \frac{E_D - E_F}{kT} = \ln n_o = \ln N_c - \frac{E_c - E_F}{kT}, \quad (3.10)$$

it follows that

$$E_F = (E_C + E_D)/2 + kT/2 \cdot \ln(N_D/N_C) \quad (3.11)$$

As you can see, at very low temperatures, the Fermi level in an *n*-type semiconductor lies midway between the bottom of the conduction band and the donor level. As the temperature increases, the probability of filling the donor states decreases, and the Fermi level shifts downward. At high temperatures, the semiconductor has properties close to its own, and the Fermi level tends to the middle of the band gap (fig. 3.2, a).

All of the considered regularities are similarly manifested in *p*-type semiconductors. The temperature dependence of the Fermi level for a hole semiconductor is shown in fig. 3.2, b.

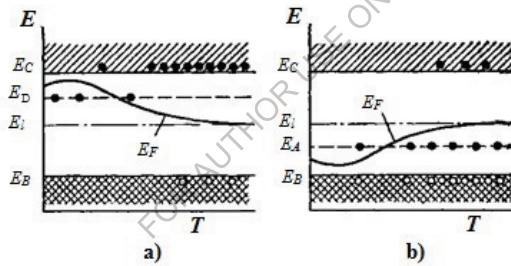

Fig. 3.2. Temperature variation of the Fermi level position in an impurity semiconductor: a - *n*-type, b - *p*-type

Having considered the effect of temperature on the concentration and mobility of charge carriers, it is possible to present the general course of change in the specific conductivity with temperature. In semiconductors with atomic lattices (as well as in ionic semiconductors at elevated temperatures), mobility changes with temperature relatively little (according to a power law), and concentration changes very strongly (according to an exponential law). Therefore, the temperature dependence of the specific conductivity is similar to the temperature dependence of the concentration (fig. 3.3).

In the temperature range corresponding to the depletion of impurities, when the concentration of the main charge carriers remains practically unchanged, temperature changes in the specific conductivity are due to the temperature dependence of mobility. A decrease in the specific conductivity in the low temperature region is associated, on the one hand, with a decrease in the concentration of charge carriers supplied by impurity atoms (donors or acceptors), and, on the other hand, with a decrease in

mobility due to scattering on ionized impurities. The sharp increase in the specific conductivity at elevated temperatures corresponds to the intrinsic conductivity region, which is characterized by the equality of electron and hole concentrations. The slope of the line in the intrinsic conductivity region can be used to determine the width of the semiconductor band gap.

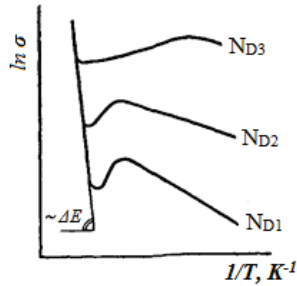

Fig. 3.3. Temperature dependence of the specific conductivity of a semiconductor at different concentrations of impurities: $N_{D1} < N_{D2} < N_{D3}$

In fig. 3.3 shows curves for different values of impurity concentration, up to the degeneration of the semiconductor. The higher the donor concentration, the more electrons are delivered to the conduction band at this temperature, and the higher the value of the specific conductivity. As the impurity content changes, the transition temperature to intrinsic conductivity also shifts. By increasing the purity of the material, it is possible to achieve the onset of intrinsic electrical conductivity even at room temperature.

In a degenerate semiconductor, the concentration of charge carriers is independent of temperature, and the temperature dependence of the specific conductivity in the impurity conductivity region is qualitatively similar to the temperature change in the specific conductivity of metals.

In real semiconductors, the temperature variation of conductivity can deviate significantly from the dependences discussed for a number of reasons. One of them is related to the fact that in practice, materials contain not one but several types of impurities with different ionization energies. Another reason for the appearance of some anomalies in the temperature dependence of conductivity may be due to the difference in the mobilities of electrons and holes.

3.3. Mobility of current carriers in semiconductors

As noted, under the influence of an external electric field, charge carriers acquire a certain speed of directional movement and generate an electric current. The ratio of the average directional velocity to the electric field intensity is called the mobility of charge carriers:

$$\mu = \bar{U}/E . \quad (3.12)$$

In semiconductors, a distinction should be made between electron mobility and hole mobility. Taking into account the two types of charge carriers, expression (2.2) for the current density takes the form:

$$J = en_o\mu_nE + ep_o\mu_pE \quad , \quad (3.13)$$

where n_o and p_o are the equilibrium concentrations of electrons and holes in the semiconductor.

Using Ohm's law from (3.13), we can obtain the formula for the specific conductivity of a semiconductor:

$$\sigma = en_o\mu_n + ep_o\mu_p \quad . \quad (3.14)$$

In impurity semiconductors, as a rule, one of the terms in expression (3.14) can be neglected. For example, at a sufficiently high concentration of donors in a semiconductor, the contribution of holes to the electrical conductivity is very small. In most cases, the mobility of holes is less than that of electrons.

According to experimental data, in some semiconductors, the mobility of charge carriers can be several orders of magnitude greater than in metals.

It has been shown that the drift velocity, and hence the mobility of charge carriers, is closely related to their free path length in the crystal:

$$\mu = \frac{e}{m^*} \tau_o = \frac{e \bar{l}}{m^* \bar{v}} \quad , \quad (3.15)$$

where m^* is the effective mass of charge carriers; \bar{v} is the thermal velocity.

High mobility can be caused by a small effective mass of the charge carrier m^* and a large value of the free run time or, more precisely, the relaxation time τ_o . In semiconductors, the effective mass of charge carriers can be either greater or less than the mass of a free electron.

The relaxation time characterizes the decrease in current after the field is removed and is determined by electron scattering processes. The higher the frequency of collisions and the more intense they are, the shorter the relaxation time and, consequently, the mobility.

The causes of charge carrier scattering in semiconductors that affect the temperature dependence of mobility are: thermal vibrations of atoms or ions in the crystal lattice, impurities, and lattice defects. Mutual scattering of electrons due to the low concentration of electron gas is neglected in the theory of semiconductors.

In semiconductors with atomic lattices, charge carrier scattering occurs due to thermal vibrations of the lattice and ionized impurities. These two scattering mechanisms lead to the appearance of two sections of the temperature dependence of mobility. Scattering by lattice thermal vibrations plays a dominant role at elevated temperatures. In the low temperature region, scattering on ionized impurity atoms is of primary importance.

Due to the low ionization energy, most of the impurity atoms are in an ionized state even at a fairly low temperature. Each ionized atom creates a Coulomb field around it. Moving charge carriers, falling within the range of this field, experience Coulomb attraction or repulsion, and as a result, distort their original trajectory. The higher the total velocity of the charge carrier, the less time it stays near the charged atom, and the lower the scattering efficiency.

Thus, if scattering of charge carriers on ionized impurities predominates, mobility increases with temperature.

If both mechanisms are involved in the scattering of charge carriers, the resulting mobility can be found using the relation:

$$\frac{1}{\mu} = \frac{1}{\mu_T} + \frac{1}{\mu_i} \quad (3.16)$$

Its temperature dependence is expressed by a curve with a distinct maximum, as shown in Fig. 3.4 for different concentrations of impurity atoms. As the impurity concentration increases, the maximum mobility decreases and shifts toward higher temperatures.

At very low temperatures, when impurities are weakly ionized, charge carrier scattering occurs on neutral impurity atoms. In the presence of this scattering mechanism alone, mobility does not depend on temperature, but is determined only by the impurity concentration.

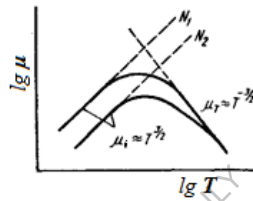

Figure 3.4. Temperature dependence of charge carrier mobility for a nondegenerate semiconductor at different impurity concentrations

The mobility of charge carriers in a semiconductor can vary greatly from sample to sample, depending on its composition and the perfection of its crystal structure.

3.4. Kinetic effects in semiconductors

a) Electrical conductivity

In the absence of an external electric field, electrons perform only thermal motion with velocities V_T . This motion is similar to the motion of atoms considered in the kinetic theory of gases. Due to the disorderly thermal motion in an electron gas in thermal equilibrium, there are no preferred directions of motion, and therefore the average thermal velocity is zero.

When an external electric field is applied, the electrons acquire additional velocities under the influence of the field. The directed motion of electrons appears. The average velocity of the ordered motion is called the drift velocity V_d . As a rule, the drift velocity is proportional to the electric field intensity E . Taking this into account, the concept of drift mobility of charged particles μ is introduced, which by definition is the drift velocity obtained by a particle in a field with a strength of one. Or it can be written:

$$V_d = \mu \cdot E \quad (3.17)$$

For electrons, mobility μ is negative, for positive particles, it is positive. If the charges are of the same type, the electric current density is equal:

$$j = enVd = en\mu \cdot E, \quad (3.18)$$

where: n is the concentration of moving charges (particles).

On the other hand, according to Ohm's law:

$$j = \sigma \cdot E, \quad (3.19)$$

where σ is the specific electrical conductivity of a substance. Hence

$$\sigma = e \cdot n \cdot \mu. \quad (3.20)$$

In isotropic substances, the drift velocity is parallel to the field and the vectors \vec{j} and \vec{E} coincide in direction. In anisotropic substances, this is no longer the case, and the relation between \vec{j} and \vec{E} has a more general form, which defines and takes into account the relationship between the directions of the current and the electric field in space:

$$\begin{aligned} \vec{J}_x &= \sigma_{xx} \cdot \vec{E}_x + \sigma_{xy} \cdot \vec{E}_y + \sigma_{xz} \cdot \vec{E}_z \\ \vec{J}_y &= \sigma_{yx} \cdot \vec{E}_x + \sigma_{yy} \cdot \vec{E}_y + \sigma_{yz} \cdot \vec{E}_z \\ \vec{J}_z &= \sigma_{zx} \cdot \vec{E}_x + \sigma_{zy} \cdot \vec{E}_y + \sigma_{zz} \cdot \vec{E}_z \end{aligned}$$

b) Hall effect

Electrons (carriers of electric charge) moving in an external magnetic field are subject to the Lorentz force perpendicular to the direction of their velocity and magnetic induction.

The Hall effect consists in the fact that in a current-carrying conductor located in a magnetic field, additional electromotive forces appear, and as a result, an additional electric field arises. The reason for this phenomenon is the Lorentz forces acting on the current carrier. The essence of the effect can be imagined as follows (fig. 3.5):

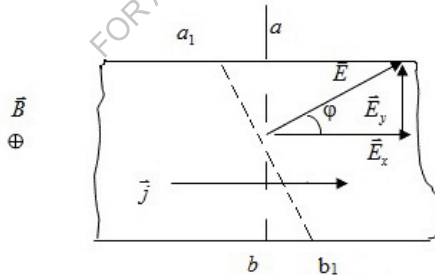

Fig. 3.5. Scheme of formation of the Hall field \vec{E}_y .

In the absence of magnetic field induction \vec{B} , the electric field strength in the conductor \vec{E} coincides with the direction of the current density \vec{j} and between two symmetrical transverse contacts a and b , located in a plane perpendicular to \vec{j} , the potential difference is zero.

When the transverse magnetic field is turned on, a potential difference U (voltage, Hall emf) appears between the open contacts a and b . This potential difference changes sign when the direction of the current or magnetic field changes and

is caused by the action of the Lorentz force on the current carriers, their deflection and the creation of a difference in the concentration (and electric charge) of the current carriers in the direction a - b .

The appearance of this potential difference shows that in the presence of a magnetic field, an additional electric field \vec{E}_y appears in the conductor. The direction of the resulting electric field \vec{E} now does not coincide with the direction of \vec{j} , but is rotated \vec{j} by a certain angle φ , which is called the Hall angle.

By considering the motion of charge carriers in an electric field and a perpendicular magnetic field for a sample of finite dimensions, a relationship between the Hall effect field strength \vec{E}_y , the Hall voltage U , and other parameters can be obtained:

$$E_y = \frac{U}{d} = R \cdot B \cdot J = R \cdot B \cdot \frac{i}{a \cdot d} \quad , \quad (3.21)$$

where: d is the thickness of the sample, a is the width of the sample, i is the total current strength, R is the proportionality coefficient, which in weak magnetic fields does not depend on magnetic induction and characterizes only the properties of the substance. It is called the Hall constant.

The Hall effect is widely used in engineering. It can be used to measure the strength of a magnetic field or, if the latter is known, to measure current and power. The Hall effect can be used to generate, modulate, and demodulate electrical oscillations, to detect oscillations, to amplify electrical signals, and so on.

c) Change of resistance in a magnetic field

External magnetic fields cause not only the appearance of the Hall field, but also change the current. This means that the resistance of a conductor in a transverse magnetic field changes. The change in conductivity $\Delta\delta$ and resistivity $\Delta\rho$ is described by the formula:

$$-\frac{\Delta\delta}{\delta} = \frac{\Delta\rho}{\rho} = \alpha \cdot B^2 \quad , \quad (3.22)$$

where δ and ρ are the values at $B=0$, and α is the transverse magnetoresistance coefficient, which depends on the material properties.

The formulas given for the Hall effect and magnetoresistance are only valid for an infinite medium. In real samples of finite dimensions, the presence of conductive metal contacts causes distortions in the current and field lines. This must be taken into account in the measurements. To keep the influence of edge effects small, the length of the samples (in the current direction) must be much longer than their cross-sectional dimensions.

d) Piezoresistance effect

The change in the electrical resistance of a semiconductor as a result of an external uniaxial mechanical stress or hydrostatic pressure is called the piezoresistance effect. Piezoresistance is characterized by the coefficient

$$\pi = \frac{\Delta\rho}{\rho\chi}$$

where χ is the value of mechanical pressure (stress).

The relationship between $\frac{\Delta\rho}{\rho}$ and χ under hydrostatic pressure is described by the components of the tensor π_{ik} :

$$\frac{\Delta\rho}{\rho} = - \frac{\Delta\delta}{\delta} = (\pi_{11} + 2\pi_{12})\chi \quad . \quad (3.23)$$

These components, as well as π_{44} , are necessary for the mathematical description and determination of the relative mechanical stress in cubic lattice semiconductors when the direction $\vec{\chi}$ and current density \vec{j} form an arbitrary angle. Table 3.1 shows various combinations of these components for the $\vec{\chi}$ and \vec{j} directions that coincide with different crystallographic axes. The vector $\vec{\chi}$ is considered positive in the case of tension and negative in the case of compression. All three components of the tensor can be determined by three measurements in different directions.

Table 3.1. Different combinations of components for directions with different crystallographic axes

	$\vec{\chi}$	\vec{j}	$\frac{\Delta\rho}{\rho\chi}$
Longitudinal components	$\langle 100 \rangle$	$\langle 100 \rangle$	π_{11}
	$\langle 110 \rangle$	$\langle 110 \rangle$	$\frac{\pi_{11} + \pi_{12} + \pi_{44}}{2}$
	$\langle 111 \rangle$	$\langle 111 \rangle$	$\frac{\pi_{11} + 2\pi_{12} + 2\pi_{44}}{3}$
Transverse components	$\langle 100 \rangle$	$\langle 010 \rangle$	π_{12}
	$\langle 110 \rangle$	$\langle 111 \rangle$	$\frac{\pi_{11} + \pi_{12} - \pi_{44}}{2}$

The experimentally determined values of the piezoresistance coefficients, for example, for p-Si with a resistivity of $\rho = 7.8 \text{ Ohm}\cdot\text{cm}$, are as follows:

$$\pi_{11} = 6,6 \cdot 10^{-11} \text{ Pa}^{-1}$$

$$\pi_{12} = -1,1 \cdot 10^{-11} \text{ Pa}^{-1}$$

$$\pi_{44} = 138 \cdot 10^{-11} \text{ Pa}^{-1}$$

e) Thermo-EMF

In semiconductors, as in metals, a potential difference occurs under the influence of a temperature difference, which is called a thermoelectromotive force (thermo-electromotive force). In a closed circuit consisting of two different conductive materials (e.g., a semiconductor and a metal), an electric current will flow if the temperature of the contacts is not the same.

Uneven heating of a homogeneous semiconductor leads to a gradient in the average energy of charge carriers in different parts of the crystal. In addition, the temperature difference can affect the change in the concentration of charge carriers, which is not observed in metals. As a result of these reasons, a diffusion flow of charge carriers occurs from the heated to the colder region of the crystal. The resulting internal electric field prevents further distribution of charges and promotes equilibrium.

In semiconductors, in general, charge carriers of two types - electrons and holes - are involved in the creation of thermo-EMF. The components of the thermoelectric emf caused by them are opposite in sign. In the absence of degeneration of the electron gas, the value of the differential thermo-emf, i.e., referred to a unit temperature difference, is determined by the expression:

$$\alpha_T = \frac{k}{\sigma} \left\{ n\mu_n \left[2 + \ln \frac{2(2\pi m_n^* kT)^{3/2}}{nh^3} \right] - p\mu_p \left[2 + \ln \frac{2(2\pi m_p^* kT)^{3/2}}{ph^3} \right] \right\}, \quad (3.24)$$

where the first term characterizes the contribution made by electrons and the second by holes. For impurity semiconductors, the formula is simplified because one of the terms can be neglected.

In an n -type semiconductor, electrons are the main charge carriers. Their flow from the hot end to the cold end will be greater than in the opposite direction. As a result of diffusion, a negative charge of excess electrons accumulates at the cold end, and a positive charge of ionized donors is formed at the hot end, which is not compensated. In a p -type semiconductor, holes are involved in the diffusion process, so the polarity of the resulting thermo-EMF will have an opposite sign. The different response of impurity semiconductors to thermal field inhomogeneities allows the thermoelectric effect to be used for rapid determination of the type of electrical conductivity of a material. A simple device designed for this purpose is called a thermoprobe. The numerical value of the differential thermoelectric emf of semiconductors, depending on the temperature and concentration of impurity atoms, ranges from 10^2 to 10^4 $\mu\text{V/K}$, i.e., 2-4 orders of magnitude higher than that of metals. This difference in material properties leads to the fact that in a closed circuit composed of a semiconductor and a metal, the thermoelectric emf is weakly dependent on the nature of the metal conductor. Therefore, when quoting the value of α_i for a semiconductor, it is usually not indicated with respect to which metal it is determined.

The high thermoelectric emf of semiconductors allows them to be used as efficient converters of thermal energy into electrical energy. The basis of such converters are thermocouples composed of p - and n -type semiconductors in series. In this case, the relative thermoelectric emf arising from the temperature difference

between the junctions is equal to the sum of the absolute differential thermoelectric emf of both branches.

3.5. Classification of semiconductor materials

Semiconductors are a very large class of materials. It includes hundreds of different substances, both individual elements and chemical compounds. Both inorganic and organic substances, crystalline and amorphous, solid and liquid, non-magnetic and magnetic, can have semiconductor properties. Despite significant differences in structure and chemical composition, materials of this class have one quality in common: the ability to change their electrical properties significantly under the influence of small external energy effects.

There is the following classification of semiconductor materials (fig. 3.6):

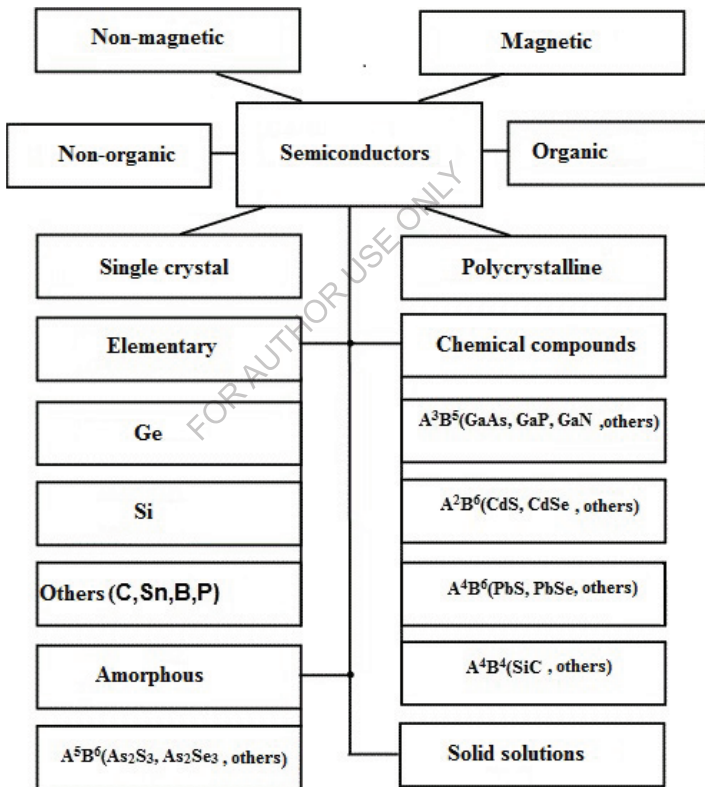

Fig. 3.6. Classification of semiconductor materials

Inorganic crystalline semiconductors form the basis of modern electronics. Semiconductor properties are exhibited by 12 chemical elements located in the middle part of the periodic table of D. I. Mendeleev. Values of the band gap of elementary semiconductors are given in various reference books on semiconductor physics (table

3.2). By arranging the elements in the order of their location in the Periodic Table, it is possible to identify some regularities in the change in the band gap - it increases in each period when moving from element to element from left to right, but decreases in each group when moving from top to bottom.

Table 3.2 Band gap of elementary semiconductors (at 300 K)

Element	ΔE_z , eV	Element	ΔE_z , eV
Boron	1,1	Arsenic	1,2
Carbon (diamond)	5,6	Antimony	0,12
Silicon	1,12	Sulfur	2,5
Germanium	0,665	Selenium	1,8
Tin (α -Sn)	0,08	Tellurium	0,36
Phosphorus	1,5	Iodine	1,25

Some modifications of tin and carbon also have semiconducting properties. The latter exists in two allotropic forms - diamond and graphite. Graphite is close to conductors in terms of electrical properties (band gap $\Delta E_z < 0.1$ eV), while pure diamonds are dielectrics. However, artificial diamonds acquire the properties of semiconductors due to the impurities introduced.

Under normal conditions, tin is a good conductor, but at temperatures below 13.2°C it transforms into the gray tin modification. The process of solid-phase transformation is very slow, which makes it difficult to obtain crystals of practical interest.

Silicon and germanium are the leading semiconductor materials in terms of their electrophysical properties, process control, number and range of manufactured devices.

A very large group of semiconductor inorganic compounds that can consist of two, three or more elements. Examples of such compounds include InSb, V_2Te_3 , ZnSiAs_2 , CuAlS_2 , and CuGe_2P_3 . The crystal structure of many compounds is characterized by coordination in the diamond lattice. Such semiconductor compounds are called diamond-like semiconductors. Among them, binary compounds of the $\text{A}^{\text{III}}\text{B}^{\text{V}}$ and $\text{A}^{\text{II}}\text{B}^{\text{VI}}$ types are of the greatest scientific and practical interest, being the most important materials for semiconductor optoelectronics.

Most diamond-like semiconductors with related properties form isovalent solid solutions with each other.

In solid solutions, the most important properties of semiconductors, such as the width of the band gap and the mobility of charge carriers, can be controlled smoothly and within a fairly wide range by changing the composition. This opens up additional opportunities for optimizing the parameters of semiconductor devices, and allows for

better matching of the physical characteristics of various components of electronic equipment.

Both single crystals and polycrystalline materials are used to make semiconductor devices. Single crystals are simpler systems with a more perfect structure than polycrystalline materials. They are the most deeply studied, their physical phenomena are better calculable, and they provide greater reliability and identical parameters of semiconductor devices.

The properties of amorphous, organic, and magnetic semiconductors have not been studied sufficiently, although the practical importance of these substances is constantly growing. A number of common features have been identified in the mechanism of electrical conductivity of amorphous inorganic and crystalline organic semiconductors. The interest in organic semiconductors is caused by the fact that some of them combine semiconductor properties with elasticity, which allows the manufacture of working elements in the form of flexible tapes and fibers.

3.6. The most common semiconductor materials are silicon, germanium, gallium arsenide, etc.

Silicon. Silicon is one of the most abundant elements in the Earth's crust, accounting for 29.5% (by weight). In terms of abundance, silicon is the second most abundant element after oxygen. Numerous silicon compounds are found in most rocks and minerals. Sand and clay, which form the mineral part of the soil, also contain silicon compounds. The most common compound of this element is silicon dioxide SiO_2 . Free silicon dioxide occurs mainly in the form of the mineral quartz. In some deposits, the purity of quartz sand reaches 99.9%. Silicon in its free state is not found in nature. In its elemental form, it was first obtained in 1811, much earlier than germanium. However, silicon became widely used as a semiconductor electronics material only in the second half of the last century after the development of effective methods for its purification.

Silicon crystallizes in the diamond structure with a slightly shorter lattice period than germanium. Smaller distances between atoms in the lattice than in germanium result in a stronger covalent chemical bond and, as a result, a wider band gap.

Chemically, crystalline silicon is a relatively inert substance at room temperature. It is insoluble in water and does not react with many acids in any concentration. It dissolves well only in a mixture of nitric and hydrofluoric acids and in boiling alkalis.

Silicon is stable in air when heated up to 900°C . Above this temperature, it begins to oxidize intensively to form SiO_2 . When heated, silicon easily interacts with halogens, and at temperatures of $1100\text{-}1300^\circ\text{C}$ it can directly combine with nitrogen to form Si_3N_4 nitride. Silicon dissolves well in many molten metals (Al, Ga, Sn, Au, Ag, etc.). With a number of metals (Cr, Mo, Fe, Cu, Mg, etc.), it forms stable chemical compounds - silicides.

Silicon has a relatively high melting point and is highly reactive in the molten state. Therefore, there are great difficulties with the selection of crucible material when growing single crystals. The purest materials (quartz and graphite), which are commonly used to make boats and crucibles, interact with silicon at high temperatures.

The reaction of silicon with carbon results in the formation of silicon carbide, a very stable chemical compound with semiconductor properties.

Due to its wider band gap, the resistivity of silicon is more than three orders of magnitude higher than that of germanium. To observe the intrinsic electrical conductivity at room temperature, the content of residual impurities in silicon should not exceed 10^{16} m^{-3} . Modern methods used to purify semiconductors do not allow for such a high degree of purity.

The behavior of impurities in silicon follows basically the same laws as in germanium. The atoms of elements of groups III and V of the periodic table, being acceptors and donors, respectively, create fine levels in the band gap. However, due to the lower dielectric constant and higher effective mass of charge carriers, the ionization energy of small donors and acceptors in silicon is significantly higher than in germanium, and for most impurities is about 0.05 eV. However, in this case, room temperature corresponds to the region of impurity depletion.

The impurities of elements of groups I, II, VI, and VII introduce deep levels into the band gap and severely limit the lifetime of nonequilibrium charge carriers. Compared to germanium, silicon has a higher limiting solubility of small donors and lower solubility of acceptors. At the same time, most impurities have a maximum solubility at temperatures of 1200-1300°C.

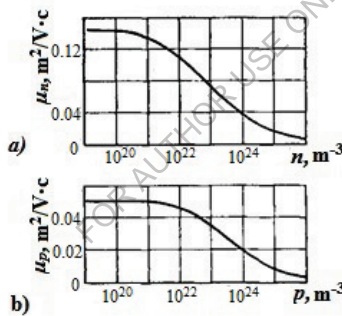

Fig. 3.7. Dependence of mobility of the main charge carriers in silicon on the concentration of electrons and holes

Figure 3.7, *a* and *b* illustrates the effect of the concentration of electrically active impurities (*n* - donors, *p* - acceptors) on the mobility μ of charge carriers in silicon. The scattering of charge carriers on ionized impurities plays a significant role at room temperature if the content of the dopant exceeds 10^{22} m^{-3} . In pure silicon crystals, the mobility of electrons is about three times higher than that of holes. The decrease in charge carrier mobility with increasing doping level of crystals is the cause of the nonlinear dependence of the specific conductivity on the concentration of dopants. Low mobility of charge carriers and limited solubility of impurities make it difficult to obtain single silicon crystals with a resistivity of less than $10^{-5} \text{ Ohm}\cdot\text{m}$. When the content of impurity atoms exceeds 10^{25} m^{-3} in a semiconductor, the formation of various complexes and microsecretions of the second phase is possible, accompanied by a change in the electrical activity of impurities. This is expressed in the discrepancy

between the concentration of charge carriers and the concentration of introduced donors and acceptors.

The main purification of silicon from impurities is carried out using chemical methods. Crystallization methods are used to transform chemically produced polycrystalline silicon into single crystals with certain electrophysical properties. Bulk single crystals of silicon are grown by melt-drawing and crucible-free zone melting. The first method is usually used to produce large single crystals with a resistivity of less than 2.5 ohm·m. The second method is used to produce high-resistance single crystals (with resistivity up to 200 Ohm·m) with a low content of residual impurities, especially oxygen.

Epitaxial deposition of thin layers plays an important role in the planar technology of silicon devices and integrated circuits. The term "epitaxy" refers to the oriented growth of one crystalline substance on the surface of another crystal that serves as a substrate. The most common industrial technology for producing silicon epitaxial layers is based on the hydrogen reduction of silicon tetrachloride according to a reaction:

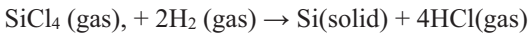

The reaction takes place in quartz reactors or at temperatures of about 1200°C. The substrates are single-crystal silicon wafers cut from ingots and subjected to mechanical and chemical polishing. The growth rate is controlled by the ratio of reagent gas flows and temperature. In optimal conditions, it is 15-20 nm/s. In practice, layers with a thickness of 2 to 20 microns are used. The layers are doped with a pair of compounds containing impurity elements (e.g., PCl_3 , BBr_3 , AsH_3 , etc.).

Relatively low operating temperatures and low crystallization rates result in high purity and structural perfection of the epitaxial layers. Epitaxial growth of structures with *p-n*-junctions has become widespread for isolation of integrated circuit elements by a region of bulk charge, the length of which increases when a reverse bias is applied to the *p-n*-junction.

In some cases, epitaxial layers of silicon are deposited on single-crystal dielectric substrates in the manufacture of integrated circuits. Various substances are used as the material of such substrates: sapphire (Al_2O_3), spinel, beryllium oxide (BeO), quartz, etc. The epitaxy of silicon on dielectric substrates opens up the possibility of creating integrated circuits with almost perfect insulation of elements.

In the manufacture of large integrated circuits, a method based on the use of polycrystalline silicon is becoming increasingly common. The peculiarity of this method is that a layer of polycrystalline silicon is deposited on the surface of silicon wafers coated with a SiO_2 dielectric film, which can act as a resistor, connections, and contact areas to the emitter and collector of the transistor. Most often, the deposition is carried out using the silane thermal decomposition method. The silane method allows for a dense, fine-grained layer structure at low temperatures (700-1000°C).

Unalloyed polycrystalline silicon films are typically characterized by a residual impurity content of up to 10^{20} m^{-3} and a resistivity of 10^4 - 10^6 Ohm·m, which is several orders of magnitude higher than that of unalloyed single crystal silicon. The higher resistivity of polycrystalline material is due to the influence of the boundaries between individual grains.

Silicon is a basic material for manufacturing planar transistors and integrated circuits. The development of planar technology for silicon devices caused a qualitative leap in semiconductor production. Semiconductor integrated circuits, characterized by very small dimensions and complex configuration of active regions, are particularly widely used in receiving and amplifying equipment and computing technology.

Despite the intensive development of integrated microelectronics, silicon discrete devices account for a significant share of the total output of semiconductor products. Rectifier, pulse and microwave diodes, low-frequency and high-frequency, high-power and low-power bipolar transistors, field-effect transistors and charge-coupled devices are made of silicon. Operating frequencies of planar transistors reach 10 GHz.

Silicon rectifier planar diodes can withstand reverse voltages of up to 1500 V and pass a forward current of up to 1500 A, significantly exceeding germanium diodes in these parameters.

Most Zener diodes and thyristors are made of silicon. Depending on the degree of doping of the material, silicon Zener diodes have a stabilization voltage of 3 to 400 V.

Silicon photosensitive devices, especially photodiodes, are widely used in technology, and are characterized by high speed. The photosensitivity spectrum of silicon photodetectors (0.3-1.1 microns) is well matched to the emission spectrum of many semiconductor light sources. Silicon photocells used to convert solar energy into electricity are called solar cells. They are used in the power supply systems of spacecraft. Their efficiency in most cases is 10-12%.

Like germanium, silicon is used to make nuclear radiation detectors, Hall sensors, and strain gauges. The latter use a strong dependence of resistivity on mechanical deformation.

Because silicon has a wider band gap than germanium, silicon devices can operate at higher temperatures than germanium devices. The upper temperature limit of silicon devices reaches 180-200 °C.

Germanium. Germanium (Ge) is common in nature but is present in very small amounts in various minerals. Its content in the Earth's crust is about $7 \cdot 10^{-4}$ %, which is approximately equal to the natural reserves of such common metals as tin and lead, and significantly higher than the amount of silver, cadmium, mercury, antimony and a number of other elements. However, obtaining germanium in its elemental form is very difficult. Minerals with a high concentration of germanium are very rare and cannot serve as raw materials for the production of semiconductors. At present, the main sources of industrial germanium production are by-products of zinc production, coal coking, and germanium concentrates obtained from copper-lead-zinc ores. Table 3.3 shows some physical parameters of germanium and silicon.

Table 3.3. Basic properties of germanium and silicon.

Properties	Ge	Si
Lattice period, nm	0,566	0,542
Density at 20°C, g/cm ³	5,3	2,3
Temperature coefficient of linear expansion (0-100°C), K ⁻¹	6· 10 ⁻⁶	2,6·10 ⁻⁶
Specific thermal conductivity W/(m·K)	55	80
Specific heat capacity (0 - 100°C), J/(kg·K)	333	710
Melting point, °C	936	1414
Surface tension coefficient at melting point, N/m	0,6	0,72
Resistivity at 20 °C, Ohm·m	0,47	2·10 ³
Intrinsic concentration of charge carriers, m ⁻³	2,5·10 ¹⁹	10 ¹⁶
Band gap, eV: at 0 K at 300 K	0,746 0,665	1,165 1,12
Electron mobility, m ² /(V·s)	0,39	0,14
Hole mobility, m ² /(V·s)	0,19	0,05
Electron output work, eV	4.8	4,3
Dielectric constant	16	12,5

Pure germanium has a metallic luster and is characterized by relatively high hardness and brittleness. Similar to silicon, it crystallizes in the structure of a diamond, whose unit cell contains eight atoms. A diamond-type crystal lattice can be viewed as the superposition of two cubic face-centered lattices offset from each other in the direction of the volume diagonal by a quarter of its length. Each lattice atom is surrounded by four nearest neighbors located at the vertices of a regular tetrahedron.

Crystalline germanium is chemically stable in air at room temperature. When heated in air to temperatures above 650°C, it oxidizes to form GeO₂.

At room temperature, germanium is insoluble in water, hydrochloric and dilute sulfuric acids. Under normal conditions, the active solvents of germanium are a mixture of nitric and hydrofluoric acids, hydrogen peroxide solution and etching agents containing oxidizing reagents. When heated, germanium reacts intensively with halogens, sulfur and sulfur compounds.

Germanium has a relatively low melting point (936°C) and a negligible saturated vapor pressure at this temperature. This circumstance greatly simplifies the technique of crystallization purification and single crystal growth. Even in the molten state,

germanium practically does not interact with graphite and quartz glass, which makes it possible to use them as crucibles and shuttles in metallurgical processes. Liquid germanium has the ability to intensively absorb hydrogen, the maximum solubility of which in the solid phase does not exceed $4 \cdot 10^{23} \text{ m}^{-3}$, and hydrogen is an electrically neutral impurity.

Under normal conditions, pure germanium is transparent to electromagnetic radiation with a wavelength of more than 1.8 microns.

At room temperature, the mobility of electrons is approximately twice that of holes. However, this ratio does not remain unchanged when the temperature changes.

For the manufacture of semiconductor devices, germanium is used with certain additions of electrically active impurities. The process of adding impurities to the base material is called alloying. The elements of groups V and III of the periodic table are most often used as donors and acceptors, respectively. These impurities create small levels in the band gap with an ionization energy of about 0.01 eV. Impurities of elements of groups I, II, VI, VII and VIII have a more complex behavior. When introduced into the germanium lattice, the atoms of most of these elements exhibit the properties of multi-charge centers, i.e., they create several rather deep levels in the band gap, due to strong differences in the valences of the impurity and base atoms.

Small donors and acceptors at temperatures above 90 K are fully ionized, so under normal conditions the concentration of charge carriers in germanium is determined by the concentration of the impurity.

In low-alloyed germanium, a positive temperature coefficient of resistivity is observed in a fairly wide temperature range, i.e., a decrease in conductivity when heated, which is due to a decrease in the mobility of charge carriers due to their scattering, which increases, on thermal vibrations of lattice nodes.

The temperature at which the intrinsic electrical conductivity begins to appear depends on the concentration of the alloying impurity. Thus, with a content of small donors of $8 \cdot 10^{19} \text{ m}^{-3}$, the intrinsic electrical conductivity occurs at 50°C , and if the donor concentration is $7 \cdot 10^{21} \text{ m}^{-3}$, then to observe the intrinsic electrical conductivity, germanium must be heated above 200°C .

For germanium to have its intrinsic electrical conductivity at room temperature, it should be purified to contain no more than 10^{19} m^{-3} impurities.

Of practical interest is the dependence of germanium resistivity on the concentration of impurity atoms (donors or acceptors). This dependence, established experimentally, is shown in fig. 3.8.a). It is used to calculate the amount of alloying impurity required to grow germanium single crystals with the required resistivity.

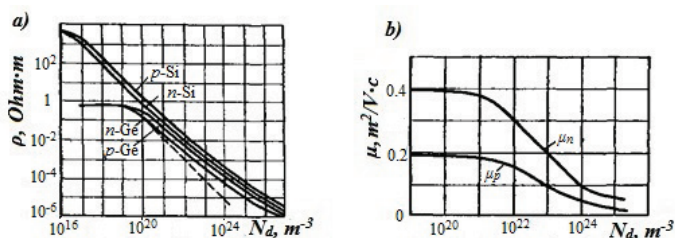

Fig. 3.8. a) - Dependence of the resistivity of silicon and germanium on the concentration of impurities at 20 °C, b) - Dependence of the mobility of the main charge carriers in germanium on the concentration of alloying impurities.

The concentration dependence of electron and hole mobility in germanium is shown in fig. 3.8.b). If the concentration of impurity atoms exceeds 10^{22} m^{-3} , scattering on ionized impurities begins to play a significant role even at room temperature. With the same degree of doping, the mobility of holes in a p-type material is always less than the mobility of electrons in an n-type material. Therefore, the dependence of the resistivity on the concentration of dopants for p-type germanium is higher than the similar dependence for n-type germanium (see fig. 3.8.a)). At concentrations of impurities less than 10^{19} m^{-3} , the resistivity of germanium is determined by its own electrical conductivity.

Heat treatment of germanium can lead to a significant change in its electrical properties. For example, if an n-type sample is heated to a temperature above 550°C , held for some time, and then quickly cooled (quenched), a change in the type of electrical conductivity of the semiconductor can be observed. Similar heat treatment of p-type germanium leads to a decrease in resistivity without changing the type of electrical conductivity. Annealing of the quenched samples at a temperature of $500\text{--}550^\circ\text{C}$ restores not only the type of electrical conductivity but also the original resistivity value. The change in properties during the hardening of samples is associated with the formation of so-called thermal acceptors in them due to structural defects.

A wide range of devices for various purposes, primarily diodes and transistors, is produced on the basis of germanium. The most widely used are rectifier planar diodes and alloy bipolar transistors.

Germanium is also used to create avalanche and tunnel diodes, varicaps, point high-frequency, pulse and microwave diodes. In pulsed diodes, a material with a short lifetime of non-equilibrium charge carriers is required to achieve a high switching speed. This requirement is met by gold-doped germanium. Gold impurities create effective recombination centers in germanium.

Due to the relatively high mobility of charge carriers, germanium is used to manufacture Hall sensors and other magnetically sensitive devices.

The optical properties of germanium allow it to be used to make phototransistors and photodiodes, optical lenses with high light output (for infrared rays), optical filters, light and short radio wave modulators, and nuclear particle counters. The operating

temperature range of germanium devices is (-60°C) to $(+70^{\circ}\text{C})$. The low upper limit of the operating temperature is a significant disadvantage of germanium.

Semiconductor compounds of the $\text{A}^{\text{III}}\text{B}^{\text{V}}$ type. $\text{A}^{\text{III}}\text{B}^{\text{V}}$ compounds are the closest electronic analogs of silicon and germanium. They are formed as a result of the interaction of elements of the III subgroup of the Periodic Table (boron, aluminum, gallium, indium) with elements of the V subgroup (nitrogen, phosphorus, arsenic and antimony). Bismuth and thallium do not form compounds of this series. $\text{A}^{\text{III}}\text{B}^{\text{V}}$ compounds are usually classified according to the metal element. Accordingly, nitrides, phosphides, arsenides, and antimonides are distinguished.

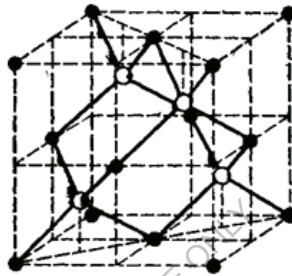

Fig. 3.9. Sphalerite structure of compounds of type $\text{A}^{\text{III}}\text{B}^{\text{V}}$: black balls - atoms A^{III} ; white - atoms B^{V}

With the exception of nitride, all $\text{A}^{\text{III}}\text{B}^{\text{V}}$ compounds crystallize in cubic zinc lattices (see fig. 3.9). Nitride is characterized by a hexagonal structure (wurtzite). In lattices of both types, each atom of a group III element is surrounded by a tetrahedron of four atoms of a group V element and vice versa. Unlike the structure of diamond, the structure of sphalerite does not have a center of symmetry. This feature leads to a difference in the properties of the surfaces (111) and $(\bar{1}\bar{1}\bar{1})$, which are composed entirely of atoms of different names. The different behavior of the (111) and $(\bar{1}\bar{1}\bar{1})$ faces is manifested during etching, oxidation, and crystal growth.

$\text{A}^{\text{III}}\text{B}^{\text{V}}$ compounds are characterized by a special type of chemical bond, the so-called donor-acceptor bond. Out of the four covalent bonds that each atom uses to build into the lattice, three are formed by sharing the valence electrons of A^{III} and B^{V} atoms, and the fourth bond is made by an unshared pair of valence electrons of B^{V} atoms. In each covalent bond, the maximum electron density is shifted toward the atom with the highest electronegativity, i.e., the electron clouds are pulled to the lattice nodes where the B^{V} atoms are located. Due to this polarization of the bonds, the A^{III} atoms acquire a certain effective positive charge, and the B^{V} atoms acquire a negative charge. The value of this effective charge ($\pm q$) determines the degree of ionicity of the compound, which naturally changes when moving from one compound to another in accordance with the position of the chemical elements in the periodic table of D. I. Mendeleev.

A valuable property of many $\text{A}^{\text{III}}\text{B}^{\text{V}}$ semiconductors is the high efficiency of radiative recombination of nonequilibrium charge carriers. To generate radiation in the

visible spectral region, the band gap of a semiconductor must exceed 1.7 eV. Among the compounds of the $A^{III}B^V$ type that have been technologically developed, gallium phosphide GaP and gallium nitride GaN meet this condition. Materials with a narrower band gap are able to radiate efficiently in the infrared region. These include, in particular, gallium arsenide, $\Delta E_z = 1.43$ eV.

The technology for producing semiconductor compounds differs from the technology for producing elementary semiconductors in that it involves a synthesis operation. To obtain non-degradable $A^{III}B^V$ compounds (antimonides), the synthesis is carried out by direct fusion of the initial components, for example, indium and antimony. Further technological operations (crystallization purification, doping, and single-crystal growth) do not fundamentally differ from those used in germanium production.

When obtaining crystals of degradable compounds, the process equipment is more complicated. The most effective method of growing single crystals of degradable compounds is to pull them out from under a layer of inert flux. A layer of liquid transparent flux, an inert gas under pressure, ensures complete sealing of the crucible and suppresses the evaporation of volatile components from the melt. As a sealing fluid, a melt of boron anhydride B_2O_3 is used, which has low chemical activity and a low softening point. The thickness of the flux layer is usually about 1 cm.

Single crystals obtained by drawing from the melt have insufficiently high chemical purity, contain a significant number of point defects in the structure, which are effective recombination traps and cause a short lifetime of nonequilibrium charge carriers. Therefore, most semiconductor devices are made on the basis of epitaxial layers deposited from the liquid or gas phase. Wafers cut from single-crystal ingots in a given crystallographic direction are used as substrates. In liquid-phase epitaxy processes, the most widely used method is the multi-chamber shuttle.

The diversity of properties of $A^{III}B^V$ semiconductors determines their wide application in instruments and devices for various technical purposes. Particular interest in this group of materials was caused by the needs of optoelectronics for high-speed radiation sources and receivers. Injection lasers and LEDs based on $A^{III}B^V$ semiconductors are characterized by high efficiency of converting electrical energy into electromagnetic radiation. Significant advantages of such devices include small dimensions, simplicity of design, the ability to modulate radiation internally by changing the control voltage, and compatibility with integrated circuit elements in terms of operating parameters and technological operations.

Thanks to this, semiconductor lasers and LEDs are successfully used in computing, information and measurement, and defense technology, in astronautics and communications, as well as in household appliances. Gallium arsenide was the first semiconductor to produce an injection laser in 1962, i.e., to generate coherent radiation using a $p-n$ junction.

A wide range of bandgap values for $A^{III}B^V$ semiconductors allows them to be used to create various types of photodetectors covering a wide range of spectra. Among them, photodiodes and photocells are the most widely used. Gallium arsenide is potentially one of the best photosensitive materials for use in solar cells. Indium

antimonide is of great technical importance for the manufacture of infrared radiation receivers.

Gallium arsenide and indium antimonide are used to make tunnel diodes. Compared to germanium diodes, gallium arsenide devices are characterized by a higher operating temperature, and InSb diodes have better frequency properties at low temperatures.

Magnetoresistors and Hall transducers are made on the basis of narrow-band semiconductors such as $A^{III}B^V$ (InSb, InAs).

Progress in gallium arsenide technology over the past decade has opened up broad prospects for the use of this material to create field-effect transistors and high-performance integrated circuits. Compared to silicon, gallium arsenide is a more technologically complex material. It is difficult to grow stable native oxide on it, and it does not allow diffusion doping with donor impurities. Decomposition at high temperatures creates difficulties in annealing operations. However, improvements in epitaxy techniques, the development of ion doping, laser annealing, electron beam lithography, and the development of new methods of deposition of protective layers make it possible to realize the potential of gallium arsenide to increase the degree of integration and performance of integrated circuits.

Silicon carbide. Silicon carbide SiC is the only binary compound formed by semiconductor elements of group IV of the periodic table. This material is extremely rare in nature and occurs in limited quantities.

By the type of chemical bond, silicon carbide is a covalent crystal. The proportion of ionic bonding due to some difference in the electronegativity of Si and C atoms does not exceed 10-12%. The strong chemical bonds between silicon and carbon atoms result in very high chemical and temperature stability of SiC, as well as high hardness.

The hexagonal modification of SiC consists of many polytypes, i.e. crystal structures that differ in the order of the atoms. Polytypism is caused by the different orientation of one layer of atoms of the same name relative to another, although all the polytypes maintain the same short-range order, i.e. each silicon atom in the crystal lattice is surrounded by a tetrahedron of carbon atoms, and vice versa. Currently, more than 100 different SiC polytypes are known. The electrophysical properties of the most common silicon carbide polytypes are systematized in the table. 3. 4.

As can be seen from Table. 3.4, the values of the band gap and electron mobility differ significantly among different polytypes. The variation of the basic electrophysical properties in different polytypes allows us to consider silicon carbide as a group of semiconductor materials with the same chemical composition.

The electrical conductivity of crystals at normal temperature is impurity. The type of electrical conductivity and color of silicon carbide crystals depend on foreign impurities or are determined by the excess of Si or C atoms over the stoichiometric composition. Pure silicon carbide of stoichiometric composition is colorless.

Table 3.4. Electrophysical properties of the main silicon carbide polytypes (T=300 K)

Modification	β - SiC		α - SiC		
	3C	15 R	6H	4H	2H
Polytope symbol	3C	15 R	6H	4H	2H
Grating period x10, nm	4,359	3,073 (a) 37,3(c)	3,081 15.12	3,076 10.05	—
Width of the forbidden zone, eV	2,39	2,986	3,023	3,265	3,333
Electron mobility, $m^2/(V \cdot s)$	0,1	0,05	0,033	0,07	—
Mobility of holes, $m^2/(V \cdot s)$	0,006	0,006	0,006	0,006	0,006

Silicon carbide is of practical interest for the manufacture of powerful rectifier diodes, high-temperature strain gauges, and high-energy particle counters that can operate in chemically aggressive environments. The possibilities of using silicon carbide to create field-effect transistors with good frequency properties, microwave diodes, thermistors, and some other devices are shown.

Varistors (nonlinear semiconductor resistors), high-temperature heaters, and waveguide absorbers are made on the basis of powdered silicon carbide bonded with a binder. Varistors are used in automation systems, computers, and electrical appliances to stabilize currents and voltages, protect circuits from overvoltage, and regulate and convert signals. Due to its high hardness, silicon carbide is used for machining various materials.

Chapter 4. Dielectrics

4.1 General information

Dielectrics are substances whose main electrical property is the ability to polarize in an electric field. In gaseous, liquid and solid dielectrics, electric charges are strongly bound to atoms, molecules or ions and can only move in an electric field, resulting in the separation of the centers of positive and negative charges, i.e. polarization. Dielectrics also contain free charges, which, moving in an electric field, cause electrical conductivity. However, the number of such free charges in a dielectric is small, so the current is low. Dielectrics used as insulating materials are called passive. There are active dielectrics whose parameters can be adjusted by changing the electric field strength, temperature, and mechanical stress. According to their chemical composition, they are divided into organic compounds of carbon with hydrogen, nitrogen, oxygen and other elements; elemental organic, whose molecules include atoms of silicon, magnesium, aluminum, titanium and other elements; and inorganic, those that do not contain carbon. Among the various properties of dielectrics that determine their technical application, the main ones are electrical conductivity, polarization, dielectric losses, electrical strength, and electrical aging. The main properties that determine the use of dielectrics in electrical and radio engineering equipment are their insulating qualities, as well as the ability to create electrical capacitance due to the existence of an internal electric field, i.e. polarization. To perform the function of electrical insulation, dielectric materials must prevent the passage of electric current through paths undesirable for the operation of the device. From this point of view, the main characteristic of dielectrics is the value of the specific electrical conductivity or resistivity.

4.2. Polarization of dielectrics

The fundamental phenomenon that determines the possibility of using a dielectric to create capacitance for capacitors in electronic equipment is polarization.

Under the influence of an electric field, electric polarization is manifested in a limited elastic displacement of bound charges, orientation of dipole molecules, as a result of which a certain volume or surface of the dielectric acquires an electric moment. After the electric field is removed, the bound charges return to their original state.

To compare dielectrics with different degrees of polarization, the concept of relative permittivity ε is used. This value is the ratio of the charge Q of a capacitor with a particular dielectric to the charge Q_0 of a capacitor of the same size and voltage with a vacuum between its linings:

$$\varepsilon = \frac{Q}{Q_0}, \quad (4.1)$$

ε is a dimensionless quantity and is always greater than one, since real dielectrics, unlike vacuum, always contain electric charges.

Dielectrics are divided into two classes: polar and nonpolar. In molecules of nonpolar substances, the centers of attraction of the total positive and negative charges

coincide. Molecules of polar materials have the form of electric dipoles that can orient themselves in an electric field.

Electronic polarization is an elastic displacement and deformation of the electronic shells of atoms and ions. The time for the establishment of electronic polarization is very short (about 10-15 s), and the process occurs with virtually no energy loss. Electronic polarization is observed in all dielectrics without exception, since all dielectrics have electrons in a bound state.

Ionic polarization is characteristic of solid dielectrics with an ionic structure (mica, corundum, rock salt) and is manifested in the elastic displacement of bound ions under the action of an electric field. In this case, the displacement of ions occurs at a distance less than the crystal lattice constant (the minimum distance between identical ions). The polarization establishment time is about 10-13 s, and no energy loss occurs.

Electron and ion relaxation polarizations are accompanied by dielectric losses. Electron relaxation polarization occurs due to the excitation of excess (defective) electrons or holes by thermal energy. Ion-relaxation polarization is characteristic of materials of ionic structure with loose packing of ions (for example, in inorganic glasses). In this type of polarization, weakly bound ions move by one or more atomic distances under the influence of a field and are fixed in a new position, which creates an asymmetry in the charge distribution and an electric moment per unit volume. The relaxation time is 10^{-11} - 10^{-8} s.

Dipole-relaxation polarization is usually observed in polar organic dielectrics (polymethyl methacrylate, polyvinyl chloride, etc.) and consists in the orientation, rotation of dipole molecules, dipole groups under the action of an electric field. This type of polarization is accompanied by energy losses. The lower the temperature and the more dipoles, the longer the relaxation time, which varies between 10^{-10} and 10^{-6} s.

Structural polarization is caused by the movement of free charges (positive and negative ions, electrons) and their fixation on defects and interfaces of different components of the electrical insulating material. This type of polarization is observed in heterogeneous dielectrics (composite plastics, getinax, textolites, ceramics, etc.), whose components have different electrical properties. The relaxation time can reach tens of minutes, and polarization is accompanied by dielectric losses.

The polarization mechanisms discussed above are characteristic of the so-called linear dielectrics, whose charge (polarizability) dependence on the electric field strength is a linear function, and the value of ϵ is independent of the field. A special group of dielectrics called nonlinear or active dielectrics is made up of ferroelectrics, which have spontaneous polarization.

At a temperature characteristic of the material and called the Curie point, individual unit cells of a ferroelectric crystal acquire a dipole electric moment due to the displacement of a cation to an anion, i.e., the creation of an asymmetric distribution of charges of different names. A set of neighboring unit cells is a region with separated positive and negative charges, i.e., a region with an internal dipole electric moment. Such regions have a size of ~ 0.1 - 1 mm³ and are called domains. Thus, under certain conditions, the material is spontaneously polarized.

Prior to the action of an external electric field, the directions of the dipole moments of individual domain regions are chaotic and their sum is zero, so the

ferroelectric is generally neutral, unpolarized. Under the action of an external electric field, the processes of displacement of domain boundaries and orientation of the electric moment vectors of domains mainly in the direction of the external field occur in a ferroelectricity, i.e., polarization increases. The dependence of the charge (polarizability) of a ferroelectric on the electric field intensity is nonlinear and in an alternating field is a dielectric hysteresis loop (fig. 4.1a). Therefore, during spontaneous polarization, the relative permittivity of the material also depends nonlinearly on the electric field strength (fig. 4.1b).

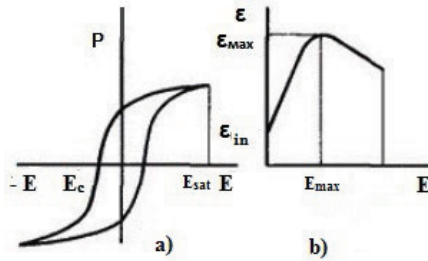

Fig. 4.1. Dependence of polarization P (a) and relative permittivity ε (b) of a ferroelectric on the electric field strength E .

Spontaneous polarization is accompanied by dielectric losses, and the area of the dielectric hysteresis loop is proportional to the loss power.

The nature of the dependence of $\varepsilon(T)$ of a particular dielectric is determined by the predominant type of polarization. In non-polar materials (polyethylene, paraffin), ε decreases with increasing temperature due to a decrease in density and, accordingly, the concentration of polarization objects. When the temperature rises up to the Curie point, the ε of ferroelectrics increases due to the facilitation of domain polarization, and above the Curie point it decreases due to the disruption of the domain structure.

4.3. Bias currents and electrical conductivity of dielectrics

Polarization processes of displacement of any charges in a substance, proceeding in time until the moment of establishment and obtaining of the equilibrium state, cause the appearance of polarization currents, or displacement currents J_{dc} in dielectrics. The displacement currents of elastically bound charges in electronic and ionic polarizations are so short-lived that they usually cannot be detected by a device. The displacement currents at different types of delayed polarization, which are observed in many technical dielectrics, are called absorption currents J_{ab} .

At a constant voltage, absorption currents, changing their direction, occur only during periods of voltage on and off. At alternating voltage, they occur during the entire time the material is in the electric field.

The presence of a small number of free charges in technical dielectrics, as well as their injection from the electrodes, leads to the appearance of small currents of conduction J_c .

Thus, the total current density in the dielectric, called the leakage current, is the sum of the absorption and transmissive current densities:

$$J_{lc} = J_{dc} + J_c. \quad (4.2)$$

The dielectrics used, as noted, contain a small amount of free charges in their volume that move in the electric field. This current is called the leakage current. In dielectrics, free charges that move in an electric field can be ions (positive and negative), electrons and electron vacancies (holes), and polarons. Electrons can acquire energy sufficient to move into the conduction band as a result of heating the dielectric or ionizing irradiation. In strong fields, it is possible to inject charges (electrons, holes) into the dielectric from metal electrodes; it is possible to form free charges (ions and electrons) as a result of impact ionization, when the energy of free charges is sufficient to ionize atoms in a collision.

Solid dielectrics are characterized by ionic electrical conductivity. When such dielectrics are heated or illuminated, exposed to radiation, or a strong electric field, defects and impurities contained in them are first ionized. The ions formed in this way determine the low-temperature impurity region of the dielectric's electrical conductivity. With more intense exposure to the dielectric, the main particles of the material are ionized. In this case, the specific conductivity changes with temperature at a higher rate, since the number of ions formed during the ionization of the main particles is greater than during the ionization of defects and impurities. The activation energy of the main particles is higher, this region of electrical conductivity is called the high-temperature intrinsic. The surface electrical conductivity of dielectrics is determined by the ability of the material surface to adsorb pollutants, in particular moisture contained in the surrounding atmosphere. Polar dielectrics are well wetted, they are called hydrophilic in contrast to hydrophobic dielectrics, which are not wetted by water. Non-polar dielectrics are hydrophobic. A thin layer of moisture on the surface reduces the surface resistance.

4.4. Dielectric losses in dielectrics

Dielectric loss is the power dissipated in a dielectric under the influence of an electric field applied to it, which causes it to heat up. We consider total dielectric losses caused by both AC and DC voltages due to currents caused by conduction.

The nature of dielectric losses in insulating materials is different and depends on the aggregate state of the substance: gaseous, liquid and solid. When studying the dielectric losses associated with the phenomenon of dielectric polarization, curves of the dependence of the charge Q on the capacitor linings with a given dielectric on the electric field voltage are considered. Losses caused by instantaneous polarizations do not heat the dielectric and are graphically represented by a linear dependence. The losses caused by any delayed polarization are expressed by the area of an oval proportional to the energy dissipated into heat per voltage period. For dielectrics with spontaneous polarization, the energy loss per period is determined by the area bounded by the hysteresis loop. Let's consider the losses in a dielectric using vector diagrams of substitution circuits.

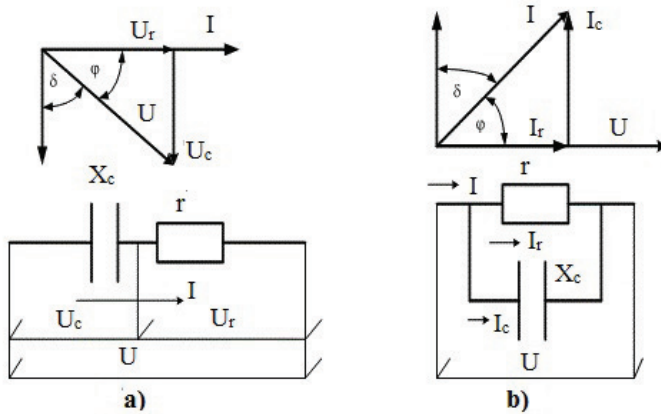

Fig. 4.2. Vector diagrams of sequential (a) and parallel (b) substitution schemes

At a constant voltage U on the insulation section with a resistance R , the value of the active loss P_a is determined as

$$P_a = U^2 / R = UI = I^2 R, \quad (4.3)$$

where I is the leakage current through the dielectric or insulation.

With a variable voltage waveform, we have the value of the heat dissipation energy W_a or active losses P_a , on the insulation section with a capacity C , at the current value of the applied voltage U , frequency f , or $\omega = 2\pi f$ (circular frequency). Here, it is necessary to find the phase angle φ between the total current and the total voltage from the vector diagrams of the series and parallel insulation replacement schemes and, adding it to 90° , find the angle δ - the angle of dielectric losses, according to figures 4.2. a), b). Moreover, the greater the power dissipation in the dielectric, which turns into heat, the smaller the phase angle φ and the greater the angle δ and, consequently, its function $\operatorname{tg} \delta$ - the tangent of the dielectric loss angle. Thus

$$W_a = P_a = UI \cos \varphi = UI \operatorname{tg} \delta = U \omega C \operatorname{tg} \delta \quad (4.4)$$

We can express $\operatorname{tg} \delta$ from the vector diagrams of fig. 4.2. a), b):

$$\operatorname{tg} \delta = U_a / U_c \text{ or } \operatorname{tg} \delta = I_a / I_c. \quad (4.5)$$

The loss factor δ is a parameter of both the material itself and the dielectric product. The term "insulation quality factor" is often used, which is the inverse of the tangent of the dielectric loss angle

$$Q = 1 / \operatorname{tg} \delta = U_c / U_r \text{ or } Q = 1 / \operatorname{tg} \delta = I_c / I_r. \quad (4.6)$$

For high-quality materials, $\operatorname{tg} \delta$ values are in the thousands and even tens of thousands of fractions of a unit, but can be higher for lower quality electrical materials (several hundredths of a unit).

The product of the relative permittivity and the dielectric loss tangent ($\varepsilon \operatorname{tg} \delta$) is called the dielectric loss factor of a material.

At alternating voltages, the losses are usually greater than at constant voltages, as shown by the inequality

$$f \rho \varepsilon \operatorname{tg} \delta > 1,8 \cdot 10^{10}.$$

This inequality relates the resistivity ρ measured at a constant voltage to the parameters ε and $tg\delta$ at an alternating voltage at a frequency f .

4.5. Electrical breakdown of dielectrics

The reliability and durability of the electrical insulation of wires, capacitor dielectrics, and other parts of electronic equipment depend on the so-called electrical strength of the dielectric. Breakdown is the loss of dielectric properties of the material in the channel formed between the electrodes under the influence of an electric field. The voltage at which the breakdown occurs is called the breakdown voltage (U_b).

The electrical strength of the dielectric E_b in a homogeneous electric field is determined by the value of the breakdown voltage U_b , related to the dielectric thickness d (distance between electrodes):

$$E_b = U_b/d. \quad (4.7)$$

In the case of an inhomogeneous field, E_b refers to the average value of the breakdown strength.

The value of E_b characterizes the ability of a dielectric to withstand the destructive effect of an electric field.

The phenomenon of breakdown is associated with the disruption of chemical bonds between molecules (atoms), ionization of substance atoms by an avalanche-like flow of electrons increasing under the influence of shock ionization. The electrical strength of a material is determined by the free path length of electrons, i.e. the density of the substance and its aggregate state.

4.6. Breakdown of solid dielectrics

Three main types of breakdown are distinguished in solid dielectrics: electrical, electrothermal, and electrochemical. The occurrence of one or another type of breakdown in a dielectric depends on its properties, electrode shape, and conditions. An electrical breakdown is a breakdown caused by shock ionization or the breaking of bonds between dielectric particles directly under the influence of an electric field.

The electrical strength E_b of solid dielectrics at electrical breakdown lies within relatively narrow limits: 100 - 1000 MV/m, which is close to the E_b of highly compressed gases and very pure liquids. The value of the E_b is mainly determined by the internal structure of the dielectric (atomic packing density, strength of their bonds) and is weakly dependent on such external factors as temperature, frequency of the applied voltage, shape and size of the sample (except for very small thickness). A very short electrical breakdown time of less than a microsecond is characteristic.

Electro-thermal breakdown is caused by a violation of the thermal equilibrium of the dielectric due to dielectric losses.

The power released in a dielectric sample with a capacitance C when a voltage U is applied to it with an angular frequency ω is determined:

$$P_n = U^2 \omega C tg\delta. \quad (4.8)$$

The heat power dissipated from the sample is proportional to the heat sink area S and the temperature difference between the sample T and the ambient T_o :

$$P_p = kS(T - T_o) \quad , \quad (4.9)$$

where k is the heat transfer coefficient.

The condition of thermal equilibrium is determined by the equality of the absorbed and dissipated powers: $P_n = P_p$. Since $tg\delta$ usually increases with increasing temperature, starting from a certain critical temperature T_k , the value of $P_n > P_p$ (fig. 4.3); another point of equality of P_n and $P_p - (T_i)$ corresponds to a stable equilibrium. As a result of the excess of heat generation over heat transfer, the dielectric is avalanche-like heated, which leads to its destruction (melting, combustion).

According to the thermal equilibrium condition, the breakdown voltage:

$$U_{bd} = \sqrt{\frac{kS(T_k - T_0)}{2\pi f C \cdot tg\delta}}, \quad (4.10)$$

where $tg\delta$ corresponds to the critical temperature T_k .

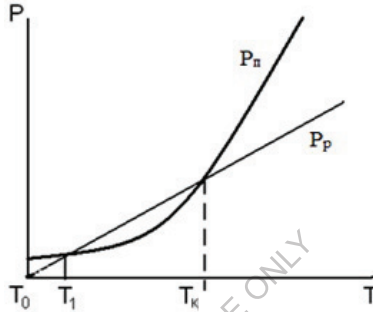

Fig. 4.3. Dependence of the power absorbed by P_n and dissipated by the dielectric sample P_p on its temperature.

Therefore, at a given operating frequency, insulation made of this material can be made with a breakdown voltage not exceeding the specified value. This voltage depends on the dielectric loss factor and other parameters.

In contrast to electrical breakdown, the voltage of electrothermal breakdown, as can be seen from (4.10), depends on frequency:

$$U_{bd} = \frac{A}{\sqrt{f}}, \quad (4.11)$$

where A is a constant (if the frequency dependence of dielectric losses is neglected).

Consequently, U_{bd} decreases at high frequencies. Similarly, U_{bd} at thermal breakdown depends on the temperature, decreasing with its increase due to the growth of $tg\delta$ [see (4.10)]. For the above reasons, with an increase in frequency f or temperature T , when the thermal breakdown voltage $U_{bd,T}$ is large, an electrical breakdown occurs, and at high f or T , when $U_{bd,T}$ decreases to values less than the electrical breakdown voltage $U_{bd,E}$, the breakdown becomes an electrothermal breakdown (fig. 4.4).

The critical frequency f_k or temperature T_k at which the transition from electrical to thermal breakdown occurs depends on the properties of the dielectric, the conditions of insulation heat dissipation, the time of voltage application, and the nature of the pulses.

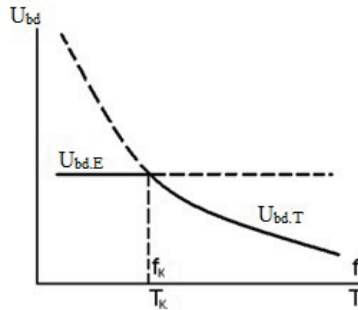

Fig. 4.4. Typical dependence of breakdown voltage on frequency and temperature.

The breakdown voltage decreases with the duration of the applied voltage due to additional heating of the dielectric, as well as chemical aging and other phenomena. With a short-term voltage application (e.g., pulsed), the probability of thermal breakdown is low even with a relatively high conductivity, since the sample does not have time to warm up.

The electrical strength of a thermal breakdown decreases with the thickness of the dielectric due to an increase in its heterogeneity and a deterioration in heat transfer.

In dielectrics that are exposed to an electric field for a long time, electrochemical breakdown can occur as a result of electrolysis, ionization of gas inclusions, and so on. These processes lead to chemical aging of the dielectric. The final stage of electrochemical breakdown is most often thermal breakdown.

Solid dielectrics have the highest electrical strength, which are homogeneous in structure, have low electrical conductivity, high thermal conductivity and heat resistance (film fluoroplastic, polyethylene, lavsan, mica, etc.). The electric breakdown field of such materials reaches 100-300 MV/m.

4.7. Passive dielectrics. Application of passive dielectric materials

Today, dielectric materials are used to manufacture numerous technical and household products. The physical properties of dielectric materials that determine their practical application were discussed above.

Dielectrics include an extremely wide range of materials of both organic (synthetic resins, rubbers, fibrous materials) and inorganic (glass, ceramics) origin. Dielectric materials in solid, liquid, and gaseous states, as well as in the form of plasma (in case of gas breakdown), are widely used in practice. Synthetic materials are those obtained by synthesis, i.e., the polymerization reaction of monomeric substances. These materials are also called polymers, plastics, and synthetic resins. Artificial materials include materials obtained by chemical processing of raw materials of natural origin (cellophane, paper, viscose, acetate). There are also many composite materials of various compositions, including both synthetic and artificial components (celluloid, laminates, phenolic plastics, aminoplastics).

There are a number of main groups of dielectric materials in the solid state: synthetic resins (plastics, polymers), elastomers, fibrous materials, laminated plastics, glasses, ceramics, and natural inorganic dielectrics.

Plastics. The main substance that forms plastics is synthetic resin. Two types of resins are used to produce plastics: thermoplastic and thermosetting. Resins that retain their ability to melt when reheated and harden when cooled are called thermoplastic.

Thermosetting resins are those that harden at elevated temperatures and turn into a non-melting and insoluble, i.e. irreversible state.

Polyethylene (CH_2-CH_2) is a synthetic resin and is a product of the polymerization of ethylene, a gas obtained by thermal decomposition of hydrocarbons or pyrolysis of liquid petroleum raw materials. Depending on the properties of the resulting polymer, there are three main groups of polyethylene: low density, medium density, and high density.

Polyethylene is characterized by high chemical resistance to aggressive environments, with the exception of mineral acids. Water is practically not absorbed by polyethylene.

The molecular weight, degree of crystallinity, degree of branching of the linear polymer, and type of supramolecular structure have a major impact on the properties of polyethylene. Currently, there are various grades of polyethylene with molecular weights ranging from 20,000 to 6,500,000. Polyethylene with a molecular weight above 100,000 is called high molecular weight polyethylene.

With an increase in molecular weight, the density and rigidity of the material decrease, but the antifriction properties, wear resistance and impact resistance improve. Optimal properties of high molecular weight polyethylene as a structural antifriction material are achieved at a molecular weight of 1,000,000. The strength properties of polyethylenes with a molecular weight of more than 1,000,000 remain virtually the same.

Polyethylene is a non-polar dielectric and is characterized by high insulating properties: $\rho \approx 10^{14}$ ohm-m; $\varepsilon = 2.3 - 2.4$; $tg \delta \sim 10^{-4}$; $E_{bd} = 15 - 20$ MV/m

Polyethylene is resistant to acids and alkalis, and is used to make chemical utensils, stoppers, and lids. High relative elongation Θ before breaking (300 - 750 %, see Table 4.1 shows approximate data for synthetic resins without fillers) creates technological advantages when molding products with complex shapes. Polyethylene is used to insulate radio frequency, telephone and power cables. Polyethylene film is used as a packaging material.

Many of the properties of polypropylene are similar to those of polyethylene, but there are fundamental differences that make it more commonly used. The elastic modulus, bending resistance, tensile strength, and plastic properties of polypropylene are better than those of high-density polyethylene (relative elongation before breaking is 400-700%).

Chemical resistance to most substances is quite high, with the exception of sulfuric and hydrochloric acids at elevated temperatures. Resistance to ultraviolet radiation is insufficient, but stabilizers are used to improve this resistance.

Table 4.1 Properties of synthetic resins

Resins	Density, mg/m ³	σ , MPa	Θ , %	Heat resistance, °C	Water absorption in 24 hours, % by weight
Polyethylene	0,91-0,97	10-15	300-750	80-90	0,01
Polypropylene	0,90-0,91	30-40	400 - 700	170	0,005
Polystyrene	1,05	35-60	1-4	70-80	0,04
Polytetrafluoroethylene	2,30	15-30	250-300	250	0,01
Polyvinylchloride	1,40-1,70	30-50	50-150	60-70	0,10
Polymethylmethacrylate	1,20	40-70	2-10	70-90	0,35
Polyamides	1,10-1,15	70-90	90	70-90	0,35

Polystyrene (Table 4.1) has a lower plasticity compared to polyethylene, i.e., a significantly lower value of relative elongation before breaking. Therefore, polystyrene exhibits brittleness (especially at low temperatures) and a tendency to gradual formation of surface cracks. The lack of strength of polystyrene is eliminated in the so-called impact-resistant polystyrene, which is obtained by copolymerizing styrene with various rubbers. The more rubber in the material, the higher its strength and resistance to impact. The dielectric properties of polystyrene are characterized by the following parameters: $\rho \approx 10^{14} - 10^{15}$ ohm-m; $\varepsilon = 2.4 - 2.6$; $\text{tg } \delta \sim 10^{-4}$; $E_{bd} = 20 - 35$ MV/m

Polystyrene is characterized by low resistance to solvents (in particular, liquid hydrocarbons) and low heat resistance. The advantages of this material, like polyethylene, include low hygroscopicity. It can be easily painted in various colors and shades.

Polystyrene and its polymers are widely used to manufacture structural elements of electronic equipment.

Polytetrafluoroethylene (PTFE). Fluoroplastics (or fluorofluorocarbons, fluoropolymers), which include PTFE, are polymers and copolymers of ethylene and propylene halides. Fluoroplastic-4 is a product of suspension polymerization of tetrafluoroethylene, and Fluoroplastic-4D is a product of emulsion polymerization of tetrafluoroethylene. Fluoroplastic-4 and modified fluoroplastic-4DM account for more than 90% of the total fluoroplastic output and are the main representatives of fluoropolymers. They are processed using methods similar to those used in powder metallurgy. PTFE products are manufactured by machining. PTFE has exceptional chemical resistance, surpassing even gold and platinum in this respect: it is unaffected by hydrochloric, sulfuric and hydrofluoric acids, as well as alkalis. The widespread use of this material is limited by its relatively high cost. Chemical glassware made of PTFE-4 is used to store only the most chemically active reagents. Polytetrafluoroethylene is non-hygroscopic and not wetted by water, has high wear resistance and ductility (Table 4.1). It is absolutely non-flammable and has an extremely wide temperature range of possible use. It can be heated to a temperature of 90-200 °C and cooled to negative temperatures within the same range. Although PTFE-4 is a thermoplastic material, it does not soften at high temperatures due to its high

molecular weight. At a temperature of 280-300 °C, it releases poisonous gaseous fluorine.

The features of PTFE-4 are its high antifriction properties and self-lubricating ability, which makes it possible to use it in the absence of lubricant access. At low sliding speeds and low loads, the coefficient of friction of the polymer on steel is 0.04. However, PTFE-4, unlike other antifriction materials, is subject to significant wear at loads exceeding 1 MPa. In terms of wear resistance, PTFE is significantly inferior to other thermoplastics, although it has the lowest coefficient of friction.

In terms of electrical insulation properties, PTFE is one of the best known dielectrics: its $\epsilon = 1.9-2.1$ at frequencies from 50 to 10^{10} Hz; $tg \delta \sim 10^{-4}$; resistivity $\rho \approx 10^{16}$ Ohm-m; $E_{bd} = 20-30$ MV/m.

Polyvinyl chloride (Table 4.1) is resistant to water, alkalis, dilute acids, oils, gasoline, and alcohol. It has low strength, which is why it is not used when subjected to mechanical stress. In addition, PVC exhibits instability of properties under the influence of heat and light. When various plasticizers are added, it is used to make plastics and rubber-like materials. Polyvinyl chloride is characterized by the following dielectric parameters: $\rho \approx 10^{13}-10^{14}$ ohm-m; $\epsilon = 3.0-5.0$; $tg \delta \sim 10^{-4}$; $E_{bd} = 15-20$ MV/m. Material properties depend on the parameters of various additives (dyes, stabilizers, plasticizers, etc.). A large number of plastics (vinyl plastics) of various degrees of elasticity, transparent and colored, have been developed on the basis of PVC.

Polyamides are polymers with a linear structure of molecules containing amide groups - CO - NH - in the chain. These materials have high chemical resistance. Dielectric parameters of polyamides: $\rho = 10^{11} - 10^{12}$ Ohm-m; $\epsilon = 3.0 - 4.0$; $tg \delta \sim 10^{-2}$; $E_{bd} = 15 - 20$ MV/m. The most common polyamides are nylon and nylon.

Polyamides are widely used for the manufacture of synthetic fibers, flexible films, etc.

Polyurethanes (PU), which are polyamides, are products of the interaction of diisocyanates with polyatomic alcohols. A significant number of polyurethanes are produced in a variety of physical forms, including hard foam, soft foam, and hard elastomers.

The dielectric properties of polyurethanes depend on the production technology and vary within a fairly wide range: $\rho = 10^{11} - 10^{14}$ ohm-m; $\epsilon = 3.0 - 4.5$; $tg \delta = 0.002 - 0.020$; $E_{bd} = 15 - 25$ MV/m.

Polyurethanes are used for enameling wires. The disadvantage is the tendency to soften the enamel film at temperatures above 150 °C.

Polyethylene terephthalate (lavan, terylene, etc.) (PET) belongs to the class of esters and is obtained by the transesterification of dimethyl terephthalate with ethyl glycol in the presence of catalysts and subsequent polycondensation of the resulting diglycol terephthalate. A distinctive feature of PET is its ability to crystallize: rapid cooling of the melt produces an amorphous polymer, and heating to a temperature of 190-200 °C produces a polymer with a crystallization rate of 55-75%.

The following dielectric parameters are typical for PET: $\rho = 10^{12}$ ohm-m; $\epsilon = 3.5 - 4.5$; $tg \delta = 10^{-2}$; $E_{bd} = 20 - 25$ MV/m.

Elastic products (elastomers) are made from natural or synthetic rubbers, which are the main component of rubber. Natural rubber (a material of plant origin) is derived

from latex, the sap of the Hevea tree, which grows in equatorial countries. Due to its low resistance to both high and low temperatures and solvents, pure natural rubber is not used. To eliminate these disadvantages, rubber is vulcanized, i.e. heated to 140 °C after sulfur (1-3%) is added to it, which produces a soft rubber with very high extensibility and elasticity. Its relative elongation before breaking is 700-800%. Natural rubber is practically non-polar: it has $\rho \approx 10^{14}$ ohm-m; $\epsilon = 2.4$; $tg \delta = 0.002$. Vulcanization leads to an increase in the polar properties of the material due to the influence of sulfur atoms. For conventional electrical insulating rubbers, $\rho \approx 10^{13}$ Ohm-m; $\epsilon = 3 - 7$; $tg \delta = 0.02 - 0.10$; $E_{bd} = 20 - 30$ MV/m.

Laminates are thermosetting materials. They are plastics in which the filler is a sheet fiber material (paper, fabric, nonwoven) with parallel layers, which determines the anisotropy of their properties.

Depending on the purpose, laminates can be divided into structural, electrical insulating, and decorative.

Depending on the chemical nature of the binder and filler, the electrical properties of electrical insulating laminates can vary widely ($\rho = 10^8$ - 10^{14} ohm-m; $\epsilon = 6$ -8; $tg \delta = (2-10)10^{-2}$; $E_{bd} = 8$ -33 kV/mm at a thickness of $h = 1$ mm). Layered plastics have a high level of mechanical properties and can be operated for a long time at temperatures up to 180 °C. The most common laminates are getinax and textolite.

Getinax is produced by pressing several layers of paper impregnated with phenol- or cresol-formaldehyde resins or their mixtures. At a temperature of 150-160 °C and a pressure of 6-10 MPa, the oligomer melts, fills the pores between the paper fibers and individual sheets, and hardens.

Foil getinax is used to manufacture printed circuit boards for low-frequency electronic devices. It is a sheet material coated on one or both sides with electrolytic copper foil (99.9%).

Textolite is a laminated plastic made of several layers of fabric pre-impregnated with a phenol-formaldehyde resin oligomer. Cotton, glass, asbestos, and nonwoven fabrics, etc. can be used as a filler.

The most common is textolite based on cotton fabric. Compared to getinax, it is much more expensive, but has higher mechanical properties. The electrical properties of textolite are about the same as those of getinax, except for lower electrical strength. Textolite is used in products subject to shock or abrasion (switch parts, etc.).

Electrical fiberglass is produced using fiberglass cloth. Foil fiberglass is also produced, which has higher moisture and heat resistance compared to foil glass reinforced polyester. The electrical strength of fiberglass textiles is almost three times higher than that of cotton textiles.

Vitreous substances (inorganic glasses) are characterized by the fact that they harden when cooled without crystallizing, forming an unsettled solid. The properties of such a body are constant regardless of the spatial direction.

Glasses are heterogeneous in structure, heterogeneous. They can contain pores and inclusions of other substances. In this case, pores make up up to 60% of the glass volume, so the electric field in it is heterogeneous, which leads to a significant decrease in electrical strength.

The most common technical glasses are silicate glasses based on SiO_2 . Glasses are divided into 1) alkaline (window, bottle, etc.) containing sodium and potassium oxides; 2) alkaline with a high content of heavy metal oxides (PbO , BaO). Glasses with a high PbO content are called flint glasses, and those with a high BaO content are called crown glasses; 3) alkali-free glasses - quartz glass, which is pure silicon dioxide SiO_2 . The latter two types are used as electrical insulating and optical glasses. They have high values of ϵ and ρ and low $tg \delta$. For example, for quartz glass, $\epsilon = 3.8$; $\rho = 10^{15}$ Ohm-m; $\epsilon = 6 - 8$; $tg \delta = 2 \cdot 10^{-4}$; $E_{bd} = 60$ MV/m.

Optical glass is used in the manufacture of eyeglass lenses and medical devices. There are seven grades of crown glass and seven grades of flint, which allows you to choose glasses with the right refractive index from 1.47 (light crown) to 1.75 (heavy flint). Colored glasses are used to make light filters for light protection of the eyes of welders, metallurgists, etc.: blue colored with cobalt and iron oxides, yellow-green colored with iron oxides with different light transmission coefficients. Most glasses are highly absorbent of ultraviolet rays due to the content of a mixture of iron oxide.

Depending on the purpose, there are several main types of electrical glass: electric vacuum, insulator, capacitor, glass enamel, and fiberglass.

Electro-vacuum glasses are used to make balloons and lamp legs for lighting lamps and various electronic devices. The most important requirement for such glasses is that the coefficients of thermal expansion of the glass and metal that are soldered together are very close.

Insulating glasses are used in the manufacture of various insulators: linear insulators, including pin and suspension insulators, station insulators, such as support and pass-through insulators, telegraph insulators, antenna insulators, etc. The electrical capacity of glass insulators, including suspended insulators, is higher than that of porcelain insulators. Insulating glasses are also widely used as sealed bushings in some types of capacitors, thermistors, silicon and germanium transistors, etc.

Capacitor glasses are used to manufacture electrical capacitors that are used in pulse generators and as high-voltage filters. For these products, it is necessary for the glasses to have high values of E_{bd} and ϵ , and for glasses for high-frequency capacitors, in addition, low values of $tg \delta$.

Glass fibers of 20-30 microns are used to make light guides. The diameter of the light guide itself reaches 5-6 mm. A light-guiding fiber consists of a core and a sheath, the material for which is selected so that the refractive index of the core is greater than the refractive index of the sheath. Therefore, heavy flint, barite flint, and extra-heavy crown glasses are used to make the core of the light-guiding fiber, and crown or light crown glasses are used to make the sheath. Glasses of these types are made on the basis of pure quartz. A light beam incident on the input end of the fiber propagates along it due to multiple total internal reflections from the core-shell interface and exits the opposite end. The quality of the light guide (light energy loss) depends primarily on the purity of the source materials and sterility at all stages of its production. For example, cheaper polymer fibers made of polymethyl methacrylate, polystyrene, etc. are used for lighting.

Sitals are polycrystalline opaque materials obtained by the directed crystallization of glasses of a special composition. The degree of crystallinity of sitals

can be 30-95%, and the size of crystallites is 0.01-2 microns, with shrinkage during crystallization reaching 2%. The name "sieve" comes from the abbreviation of the words "silicate" and "crystal". In the manufacture of sieves, special additives are introduced into the glass mass to form crystallization centers (nuclei). Depending on the nature of the additive and the subsequent crystallization process, thermosynthetics and photosynthetics are distinguished.

The electrical properties of sieves are usually higher than those of glasses of the same composition, and compared to ceramics, sieves of the same composition have a higher permittivity: $\varepsilon = 5-7$, $\rho = 10^{10}-10^{12}$ Ohm-m; $tg \delta = (1 - 80) \cdot 10^{-3}$; $E_{bd} = 20-80$ MV/m, operating temperature range from -50 to 700 °C.

Sitals are used as substrates for thin-film and hybrid microcircuits and as supports for mounting arresters.

Ceramic materials (porcelain and earthenware) are obtained by firing a mixture made from clay with the addition of quartz (sand) and feldspar at high temperature. The ceramic production process takes place in three main stages: 1) preparation of the ceramic mass by cleaning its constituent components from impurities, grinding them thoroughly and mixing them with water into a homogeneous mass; 2) forming a product of a given configuration and size by pressing, extruding or casting; 3) drying and firing.

Ceramic materials can be very diverse in terms of their properties and applications. Porcelain products are highly resistant to thermal aging. Porcelain has a high compressive strength (400-700 MPa), a much lower tensile strength (45-70 MPa) and bending strength (80-150 MPa), and increased impact fragility.

The main representative of low-frequency ceramics is electro porcelain, which is widely used to make insulators. Unlike other types of ceramics, electro porcelain has lower electrical and mechanical properties. The advantages are the ability to manufacture products of complex configuration using simple technological processes and low-scarcity raw materials.

Polycor (Al_2O_3) has a particularly dense structure and, unlike conventional (opaque) corundum ceramics, is transparent, so it is used to make flasks for some special electric light sources. It has a ρ an order of magnitude higher than opaque alumina ceramics.

Ceramic dielectrics are characterized by a high resistivity ($\rho \approx 10^{14}$ Ohm-m) and a low dielectric loss tangent ($tg \delta = 10^{-4} - 10^{-3}$) even at elevated temperatures (up to 1000 °C). The value of $\varepsilon = 6 - 10$. In the production of capacitors, ceramic materials are used - ferroelectrics with a high ε (up to 10,000 and more).

Natural mineral inorganic dielectrics include mica and asbestos. Mica has high electrical insulating properties, heat resistance, mechanical strength, and flexibility. In thin layers, many types of mica are transparent.

Mica occurs in the form of crystals that can be easily split into thin plates along parallel planes. By chemical composition, mica is an aqueous aluminosilicate.

The actual composition of natural mica is much more complex due to the presence of impurities.

The working temperature of mica (500-900) °C is limited by the release of water included in its composition, which is associated with a loss of transparency, an increase

in thickness ("swelling") and the destruction of the crystalline structure; dehydrated mica melts at a temperature of 1250 - 1300°C. The ϵ value of mica is 6 - 8; $tg \delta \sim 10^{-4}$; $\rho = 10^{11} - 10^{14} \text{ Ohm}\cdot\text{m}$.

4.8. Active dielectrics

a) Classification of active dielectrics

Active dielectrics are dielectrics whose properties can be controlled by external energy effects and used to create functional electronics elements. Active dielectrics allow for the generation, amplification, modulation of electrical and optical signals, and the storage or conversion of information. With the increasing complexity of electronic equipment and the transition to functional electronics, the role and importance of active materials in solving the most important scientific and technical problems are constantly growing.

Active dielectrics include ferroelectrics, piezoelectrics, pyroelectrics, electrets, quantum electronics materials, liquid crystals, electro-, magneto- and acousto-optical materials, dielectric crystals with nonlinear optical properties, etc.

Active dielectrics can be used not only for solids, but also for liquids and even gases (e.g., the active medium of gas lasers). In terms of chemical composition, these can be organic and inorganic materials. According to their structure and properties, they can be divided into crystalline and amorphous, polar and nonpolar dielectrics. A number of materials exhibit their activity only due to the presence of spontaneous or stable residual polarization. However, the polarized initial state is not a prerequisite for the material to be active under external influences. A strict classification of active dielectrics, which encompasses many features of these materials, is very difficult. Moreover, there is no sharp line between active and passive dielectrics. The same material can perform either the passive functions of an insulator or capacitor, or the active functions of a control or transducer element under different operating conditions.

Depending on the technical application, the requirements for materials also vary significantly. For example, one of the main requirements for passive dielectrics is to maintain the stability of their properties under external influences. At the same time, the requirements for an active material are quite the opposite: the more its properties change under external influences, the better the active element can perform the functions of energy management or transformation of incoming information.

In most cases, active dielectrics are classified according to the kind of physical effects that can be used to control the properties of materials. However, such a classification, while quite logical and reasonable, does not allow for a clear separation of one group of materials from another.

b) Ferroelectric

A ferroelectric is a substance that has a spontaneous polarization whose direction can be reversed by an external electric field.

In the absence of an external electric field, ferroelectrics typically have a domain structure. Domains are macroscopic regions that have spontaneous polarization that occurs under the influence of internal processes in the dielectric. The directions of electric moments in different domains are different. Therefore, the total polarization of

the sample as a whole can be zero. In principle, if a crystal is small, it can consist of only one domain. However, large samples are always split into many domains, since a single-domain state is energetically disadvantageous. The division into domains reduces the electrostatic energy of the ferroelectric.

In a single crystal, the relative orientation of the electric moments of the domains is determined by the symmetry of the crystal lattice. The most energetically advantageous structure is one that ensures the electrical neutrality of domain boundaries, i.e., the projection of the polarization vector on the boundary from one domain should be equal in length and opposite in direction to the projection of the polarization vector from the neighboring domain.

The external electric field changes the directions of the electric moments of the domains, which creates the effect of very strong polarization. This explains the ultra-high dielectric constant (up to hundreds of thousands) inherent in ferroelectrics. Domain polarization is associated with the processes of nucleation and growth of new domains due to the displacement of domain boundaries, which eventually cause a reorientation of the spontaneous polarization vector in the direction of the external electric field.

If the field strength is reduced to zero in a sample polarized to saturation, the induction does not go to zero, but acquires some residual value. Under the action of a field of opposite polarity, the induction decreases rapidly and at a certain field strength changes its direction. A further increase in the field strength again brings the sample to a state of technical saturation. It follows that the repolarization of a ferroelectric in alternating fields is accompanied by dielectric hysteresis. The field strength at which induction goes through zero is called the coercive force.

Dielectric hysteresis is caused by the irreversible displacement of domain boundaries under the influence of a field and indicates an additional mechanism of dielectric losses associated with the energy expenditure for domain orientation. The area of the hysteresis loop is proportional to the energy dissipated in the dielectric during one period. The nonlinearity of polarization with respect to the field and the presence of hysteresis determine the dependence of the dielectric constant and capacitance of the ferroelectric capacitor on the operating mode. To characterize the properties of the material under different operating conditions of a nonlinear element, the concepts of static, reversible, effective, and other dielectric constant are used.

The specific properties of ferroelectrics are only manifested within a certain temperature range. When heated above a certain temperature, the domain structure breaks down and the ferroelectric material becomes paraelectric. The temperature T_c of this phase transition is called the ferroelectric Curie point. At the Curie point, the spontaneous polarizability disappears and the dielectric constant reaches its maximum value.

Several hundred ferroelectrics are currently known. The group is significantly supplemented and expanded by solid solutions based on various compounds. Thus, ferroelectricity is a fairly widespread phenomenon in dielectrics. At the same time, ferroelectric crystals are characterized by a variety of structural types, which indicates a difference in the molecular mechanisms of spontaneous polarization. The

temperature of transition to the spontaneously polarized state (Curie point) for different ferroelectrics ranges from several kelvins to one and a half thousand kelvins.

According to the type of chemical bonding and physical properties, all ferroelectrics are divided into two groups: 1) ionic crystals; 2) dipole crystals.

In compounds of the first group, the characteristic structural element of the crystal lattice is an oxygen octahedron, which is why these materials are called oxygen-octahedral type ferroelectrics. Ionic ferroelectrics include barium titanate (BaTiO_3), lead titanate (PbTiO_3), etc.

For the first time, peculiarities in the behavior of dielectrics were discovered in crystals of selenium salt due to spontaneous polarization. Hence the name of the entire group of materials with specific properties - ferroelectrics.

The vast majority of ferroelectrics of the first group have a much higher Curie temperature and a higher spontaneous polarizability value than ferroelectrics of the second group. For a significant part of dipole ferroelectrics, the Curie point is much lower than room temperature.

c) Piezoelectrics

Piezoelectrics are dielectrics that have a strong piezoelectric effect. The direct piezoelectric effect is the phenomenon of dielectric polarization under mechanical stress. This phenomenon was discovered by the Curie brothers in 1880. The electric charge generated on each surface of a dielectric varies according to a linear law depending on the mechanical force:

$$Q = kF; \quad Q/S = kF/S, \text{ or } q_s = P = k\sigma, \quad (8.1)$$

where Q is the charge; k is the piezomodule; F is the force; S is the area; q_s is the charge per unit area; P is the polarizability; σ is the mechanical stress in the dielectric cross-section.

The reverse piezoelectric effect is a phenomenon in which a mechanical deformation of a dielectric occurs under the action of an electric field. The deformation of the piezoelectric depends on the direction of the electric field and changes sign when the direction of the latter changes. There are also longitudinal and transverse piezoelectric effects. The former is understood as an effect where the appearance of charges on opposite faces of the plate is determined in the same direction as the mechanical force, and the latter is understood as a deformation measured in the direction of the applied electric field. With the transverse piezoelectric effect, the resulting charges or strains are measured in the direction perpendicular to the direction of the mechanical force or electric field, respectively.

The piezoelectric effect is observed only in substances with heteropolar chemical bonding, i.e., either ionic or strongly polar dielectrics can be piezoelectrics. The second necessary condition for the existence of the piezoelectric effect is the absence of a center of symmetry in the dielectric structure. Otherwise, the deformation causes a symmetrical displacement of positive and negative charges, and no electric moment occurs. Only substances with high resistivity can be piezoelectrics. In conductive media, piezoelectric polarization is quickly compensated for by free charge carriers. Since any dielectric has some leakage current, all applications of the piezoelectric effect are associated with variable processes.

More than a thousand substances are known to have piezoelectric properties, including all ferroelectrics. However, only a limited number of materials are used in practice. One of the most important among them is single-crystal quartz. It is one of the modifications of silicon dioxide.

Large natural transparent quartz crystals are called rock crystal. Usually, natural crystals have the shape of a hexagonal prism, which reflects the symmetry of the internal structure.

A plane-parallel polished quartz plate with electrodes and a holder is a piezoelectric resonator, i.e., it is an oscillating circuit with a certain resonant frequency. The latter depends on the thickness of the plate and the direction of the crystallographic cut. The advantages of quartz resonators are their low $tg \delta$ and high mechanical quality factor (i.e., very low mechanical losses). In the best quartz crystals, the mechanical Q factor can be 10^6 - 10^7 . A quartz piezoelectric element placed in the input circuit of an electric generator imposes its own resonant frequency on it.

Due to their high quality, quartz resonators are used as filters with high selectivity, as well as for stabilizing and standardizing the frequency of oscillators (in radar stations, electronic watches, etc.).

Given the limited reserves of natural quartz, the main needs of piezoelectric engineering are met by artificially grown crystals. They are produced by the hydrothermal method. Crystallization occurs from aqueous alkaline solutions in large-capacity steel autoclaves at a temperature of 350 - 400°C and a pressure of about 10^8 Pa. Due to the low solubility of silica in aqueous solutions, the duration of one growth cycle is several months.

In addition to quartz, various piezoelectric transducers use crystals of lithium sulfate, selenium salt, ammonium dihydrogen phosphate, as well as lithium niobate and tantalate. The latter are a significant competitor to quartz, surpassing it in terms of quality factor in the high and ultra-high frequency range.

The most widely used piezoelectric material is ferroelectric ceramics. In the normal state, ferroelectric ceramics do not exhibit piezoelectric activity because they are an isotropic medium due to the chaotic arrangement of individual crystal grains and their division into domains with different directions of spontaneous polarization. However, if the ferroelectric ceramics are subjected to a strong electric field, the polarization of the domains will be predominantly oriented in one direction. After the field is removed, a stable residual polarization remains. In terms of its properties, the polarized ferroceramic sample is close to a single-domain crystal, i.e., it has high piezoelectricity.

Polarized ferroelectric ceramics intended for use in piezoelectric transducers are called piezoelectric ceramics. Piezoceramics have the advantage over single crystals that they can be used to make an active element of almost any size and shape (for example, a hollow cylinder that is part of a sonar).

The main material for the manufacture of piezoelectric elements is lead zirconate titanate. This ceramic is widely used to create powerful ultrasonic emitters in a wide frequency range for the purposes of hydroacoustics, flaw detection, and material processing. Such ultrasonic generators are also used in the chemical industry to accelerate various processes (emulsifiers, polymerizers, sterilizers, etc.) and in

semiconductor technology for the efficient washing and degreasing of semiconductor wafers using an ultrasonic bath. Small-sized microphones, telephones, loudspeakers (high-frequency), hearing aids, detonators, and various ignition devices in gas systems are made of piezoceramics. Piezoceramic elements can be used as sensors of pressure, deformation, acceleration, and vibration. The double conversion of energy (electrical to mechanical and vice versa) is the basis for the operation of piezoresonant filters, delay lines and piezoelectric transformers.

Piezoelectric transformers are designed to produce high voltage. An alternating electric field applied to the exciter clamps causes resonant mechanical vibrations along the length of the bar. In turn, the mechanical vibrations occurring in the generator part lead to the appearance of the output electric voltage. Transformers can be designed to operate in the frequency range of 10-500 kHz.

d) Pyroelectrics

The pyroelectric effect is a change in the spontaneous polarizability of dielectrics with temperature. Pyroelectrics are dielectrics that have a strongly pronounced pyroelectric effect.

The quality of a pyroelectric material is usually characterized by the following physical parameter

$$R_B = p/(\varepsilon c) , \quad (4.12)$$

where p is the pyroelectric coefficient, ε is the dielectric constant, and c is the specific volume heat capacity.

The higher the value of R_B , the greater the potential difference that can be obtained on the sample with the same absorbed power.

Some linear dielectrics (e.g., tourmaline, lithium sulfate) and all ferroelectric materials have pyroelectric properties. The peculiarity of linear pyroelectrics is that, unlike ferroelectrics, the direction of spontaneous polarization cannot be changed by an external electric field.

Ferroelectrics exhibit pyroelectric properties only in the monodomain state, which is characterized by the same orientation of the spontaneous polarization of all domains. In a polydomain sample, the total polarizability is zero, and therefore there is no pyroelectric effect. The monodomainization of a ferroelectric is carried out by keeping it in a constant electric field at a temperature slightly below the Curie point. The creation and consolidation of a monodominated state in ferroelectric crystals is one of the most important problems when using them as pyroelectrics.

The temperature change in spontaneous polarizability is due to two main reasons. On the one hand, an increase in temperature disrupts the orderliness of the arrangement of elementary dipole moments (primary or true pyroelectric effect), and on the other hand, heating causes a change in the linear dimensions of the dielectric and piezoelectric polarization due to strain.

The significant pyroelectric effect in ferroelectrics is used to create thermal sensors and radiant energy receivers.

The maximum values of pyroelectric coefficients are obtained for ferroelectrics with a Curie point close to room temperature. These include barium-strontium niobate crystals ($\text{Sr}_x\text{Ba}_{1-x}\text{Nb}_2\text{O}_6$), which have $p = (4-28)10^{-4} \text{ Cl/m}^2 \cdot \text{K}$. The highest value of R_B

($8.5 \cdot 10^{-12}$ m/V) is observed for triglycine sulfate crystals. Due to the good combination of properties and the comparative simplicity of the technology for obtaining large crystals, this material is widely used in low-frequency radiation detectors. Hygroscopicity is somewhat inconvenient, which necessitates its special sealing in practical devices.

LiNbO_3 and LiTaO_3 crystals are characterized by increased sensitivity at high frequencies and are distinguished by stable pyroelectric properties. Due to their high Curie temperature, they do not require special techniques for fixing the monodomain state and can operate stably up to temperatures of about 500°C .

The pyroelectric effect is also manifested in polarized ferroelectric ceramics, although the pyroelectric properties of polycrystalline samples are noticeably worse than those of single crystals. All types of piezoceramics can be used to manufacture photodetectors, but the most suitable material for these purposes is lead zirconate titanate ferroelectric ceramics. The introduction of lanthanum oxide additive makes it possible to bring the Curie temperature closer to room temperature and to obtain higher pyroelectric coefficients.

e) Liquid crystals

Liquid crystals are substances that are in an intermediate (mesomorphic) state between an isotropic liquid and a solid crystal body. On the one hand, they have fluidity and the ability to be in a droplet state, and on the other hand, they are characterized by anisotropy of properties and, above all, optical anisotropy.

The small intermolecular forces that ensure the ordered structure of a liquid crystal are the fundamental basis for the strong dependence of properties on external factors (temperature, pressure, electric field, etc.). This dependence, in turn, opens up rich opportunities for the development of indicator devices for various purposes. Liquid crystals were discovered in 1888 by Austrian botanist F. Reinitzer. However, these substances have found wide practical application relatively recently. The specificity of liquid crystals lies in the limited temperature range of the mesophase (liquid crystal state). The liquid crystalline state is formed mainly by organic compounds with elongated rod-shaped molecules. A significant part of liquid crystals are compounds of the aromatic series, i.e. compounds whose molecules contain benzene rings.

Currently, more than 3000 organic compounds are known to exist in the mesomorphic state. Among them, there are also substances in which the temperature range of the mesophase includes room temperature.

Based on their general symmetry, all liquid crystals are divided into three types: smectic, nematic, and cholesteric.

The smectic phase is characterized by a layered structure (fig. 4.5, a). The centers of gravity of elongated molecules are in planes equidistant from each other. In each layer, the molecules are oriented in parallel due to elastic dispersion interaction. Fluidity is provided only by the mutual sliding of the layers, so the viscosity of the medium is quite high. Because of their high viscosity, smectic liquid crystals are not widely used in engineering.

In the nematic phase, the long axes of the molecules are oriented along one common direction, called the nematic director. However, the centers of gravity of the

molecules are randomly arranged, so that a lower-order symmetry than in smectic crystals occurs (fig. 4.5, b). With this structure of the substance, mutual sliding of molecules along the nematic director is possible.

The cholesterol phase is similar to the nematic phase at the molecular level. However, its entire structure is additionally twisted around the Witt axis, which is perpendicular to the molecular axes. The result is a layered helical structure with a helix pitch of about 300 nm (fig. 4.5, c). Such a phase behaves in relation to the incident radiation like an interference filter, i.e., light rays are selectively reflected. The phenomenon is in many ways analogous to the diffraction of X-rays on the crystal lattices of solids.

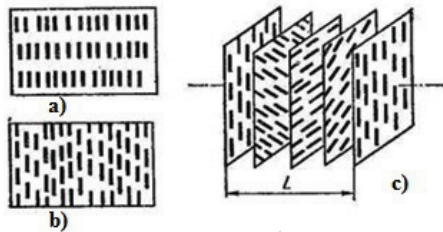

Fig. 4.5. Schematic representation of the structure of liquid crystals:
a - smectic; b - nematic; c - cholesteric

If a flat layer of a cholesterol liquid crystal is illuminated with white light, it will appear colored in the reflected light, and the color may vary depending on the angle of observation.

The pitch of a helical spiral is highly dependent on external influences. When the temperature changes, the distance between the molecular layers changes, and the wavelength of maximum scattering at a given angle of observation changes accordingly. The result is a color thermometer that has found various applications. The change in texture color with temperature is called the thermochromic effect. Color thermometers are successfully used for technical and medical diagnostics. They make it very easy to get a picture of the thermal field in the form of a color chart.

For controlling a light beam and for visual display of information, electro-optical effects in nematic liquid crystals are of the greatest practical interest. As with ferroelectrics, the entire volume of a nematic liquid crystal is divided into small regions - domains - that differ in the direction of their preferred orientation, resulting in optical heterogeneity of the medium and strong light scattering. Such a liquid crystal appears cloudy in the reflected and transmitted light. For practical use, thin, homogeneously oriented layers are required. In this case, a distinction is made between homogeneous (horizontal) and homeotropic (vertical) orientation of the molecules relative to substrates made of glass. The required orientation is achieved by special surface treatment of glass substrates (etching, rubbing, scribing, deposition of organic and inorganic coatings, etc.) or by the introduction of surfactants into the mesophase.

In terms of electrical properties, nematic liquid crystals belong to the group of polar dielectrics with a low resistivity ($\rho = 10^6$ - 10^{10} Ohm-m), the value of which can be

easily adjusted by dissolving dissociating ionic compounds. Optical and dielectric anisotropy are important characteristics of nematic liquid crystals. A measure of optical anisotropy is the difference $\Delta n = n_{\parallel} - n_{\perp}$ (where n_{\parallel} and n_{\perp} are refractive indices for a light wave whose electric vector is either parallel or perpendicular to the direction of the predominant orientation of the molecules. Respectively, an unusual and an ordinary ray).

When creating information display devices on liquid crystals, the most widely used are the effect of dynamic light scattering and the field "twist" effect (unwinding of the nematic phase).

Dynamic light scattering is observed in liquid crystals with negative dielectric anisotropy and low resistivity (about 10^6 Ohm·m). The homeotropic orientation of the mesophase molecules corresponds to the initial state. Due to its internal orderliness, the medium is transparent to incident light. Under the influence of an external voltage, the dipoles rotate (their electric moment is perpendicular to the long axes of the molecules) and the orientation changes to homogeneous. At the same time, a strong electric field initiates a flow of ions, which disrupts the ordered static arrangement of the molecules. When the molecular axes are aligned in the direction of the ion flow, turbulence occurs in the mesophase, which leads to local changes in the refractive index, i.e., light-scattering centers appear. Externally, this manifests itself as a turbidity of the medium. The intensity of light scattering, and thus the contrast of the optical response, increases with an increase in the control voltage. The geometry of the illuminated character is determined by the shape of the electrode. When the field is turned off, the medium returns to its original transparent state.

To obtain color images, dye molecules are introduced into liquid crystals, which also have an elongated stick-like shape and are oriented parallel to the mesophase molecules due to elastic dispersion interaction. The absorption spectrum of such molecules is a function of their orientation relative to the direction of polarization of the incident light. Absorption is maximized if the long axes of the molecules are parallel to the oscillations of the electric vector of the light wave. An external field changes the static orientation of the molecules, which changes the absorption spectrum of linearly polarized light and the resulting color contrast of the electro-optical cell.

Liquid crystals used in indicator devices are usually a mixture of two or more compounds. In mixed systems, it is possible to obtain a wider temperature range of the mesophase.

The field of application of nematic liquid crystals is still mainly limited to display devices. Such devices include displays, large-format scoreboards, digital indicators for microcomputers, electronic clock faces, and digital measuring instruments. The main advantages of such indicators are: a) good contrast in bright light; b) low power consumption; c) compatibility with integrated circuits in terms of operating parameters and design; d) comparative ease of manufacture and low cost. Liquid crystals use ambient light for display, so their power consumption is much lower than in other display devices and amounts to 10^{-4} - 10^{-6} W/cm². This is several orders of magnitude lower than in LEDs, powder and film phosphors, and gas-discharge indicators. The main disadvantages of liquid crystal devices are their low speed and susceptibility to electro- and photochemical aging.

Chapter 5. Magnetic materials

5.1. General concepts of magnetism

According to the nature of interaction with the magnetic field, materials are usually divided into weakly interacting and strongly interacting materials. A measure of the interaction of materials with a magnetic field is magnetic induction (B), i.e., the average magnetic field strength inside the material when it is in an external magnetic field with a strength of H . Magnetic induction is the superposition of the external magnetic field strength and magnetization:

$$B = \mu_o(H + M), \quad (5.1)$$

where M is the magnetization of the material, i.e., the ratio of the vector sum of elementary magnetic moments to the volume of the material, $\mu_o = 4\pi \cdot 10^{-7}$ Gn/m is the magnetic constant.

In substances that interact weakly with the field, the magnetization is small $B \approx \mu_o H$. Such substances include diamagnets and paramagnets. In diamagnets, the induction is lower than the external field strength, and in paramagnets, the induction is higher than the external field strength. Substances that interact strongly with the field have a high magnetization. Such substances include ferromagnets, antiferromagnets (ferrites), supermagnets, and spin glasses.

5.2. Classification of magnetic materials

According to the reaction to an external magnetic field and the nature of their internal magnetic ordering, all substances in nature can be divided into five groups: diamagnets, paramagnets, ferromagnets, antiferromagnets, and ferromagnets. These types of magnets correspond to five different types of magnetic states of matter: diamagnetism, paramagnetism, ferromagnetism, antiferromagnetism, and ferromagnetism.

Diamagnets are substances whose magnetic susceptibility is negative and does not depend on the strength of the external magnetic field.

Diamagnetism is caused by a slight change in the angular velocity of the orbital rotation of electrons when an atom is placed in a magnetic field. The diamagnetic effect is a manifestation of the law of electromagnetic induction at the atomic level. The electron orbit can be considered as a closed circuit with no active resistance. Under the influence of an external field, the current in the circuit changes and an additional magnetic moment is generated. According to Lenz's law, this moment is directed toward the external field. The diamagnetic effect is universal, inherent in all substances. However, in most cases it is masked by stronger magnetic effects. The diamagnetism of electron shells comes to the fore when the intrinsic magnetic moment of atoms is zero.

Diamagnetics include inert gases, hydrogen, nitrogen, many liquids (water, oil and its derivatives), a number of metals (copper, silver, gold, zinc, mercury, gallium, etc.), most semiconductors (silicon, germanium, etc.) and organic compounds, alkaline-halide crystals, inorganic glasses, etc. Diamagnets are all substances with covalent chemical bonds and substances in the superconducting state.

The numerical value of the magnetic susceptibility of diamagnetics is 10^{-6} - 10^{-7} . Since diamagnetics are magnetized against the field direction, the inequality $\mu < 1$ is fulfilled for them. However, the relative magnetic permeability differs very little from unity (except for superconductors). The magnetic susceptibility of diamagnets changes very little with temperature. This is due to the fact that the diamagnetic effect is caused by intra-atomic processes that are not affected by the thermal movement of particles. An external manifestation of diamagnetism is the ejection of diamagnets from an inhomogeneous magnetic field.

Paramagnets are substances with a positive magnetic susceptibility that does not depend on the strength of an external magnetic field. In paramagnetics, atoms have an elementary magnetic moment even in the absence of an external field, but due to thermal motion, these magnetic moments are distributed randomly so that the magnetization of the substance is generally zero. An external magnetic field causes the magnetic moments of atoms to be predominantly oriented in one direction. Thermal energy counteracts the creation of magnetic order. Therefore, paramagnetic susceptibility is strongly temperature dependent.

At room temperature, the magnetic susceptibility of paramagnets is 10^{-3} to 10^{-6} . Therefore, their magnetic permeability is slightly different from unity. Due to their positive magnetization, paramagnets placed in an inhomogeneous magnetic field are attracted to it. In very strong fields and at low temperatures, paramagnets can reach a state of magnetic saturation, in which all elementary magnetic moments are oriented parallel to H .

Paramagnets include oxygen, nitric oxide, alkali and alkaline earth metals, some transition metals, salts of iron, cobalt, nickel, and rare earth elements. The paramagnetic effect is physically similar to the dipole-relaxation polarization of dielectrics.

Ferromagnets are substances with a large positive magnetic susceptibility (up to 10^6), which strongly depends on the magnetic field strength and temperature. Ferromagnets are characterized by internal magnetic ordering, which is expressed in the existence of macroscopic regions with parallel oriented magnetic moments of atoms. The most important feature of ferromagnets is their ability to be magnetized to saturation in relatively weak magnetic fields.

Antiferromagnets are substances in which the antiparallel orientation of the elementary magnetic moments of identical atoms or ions in the crystal lattice spontaneously arises below a certain temperature. Antiferromagnets are characterized by a small positive magnetic susceptibility ($\chi = 10^{-3} - 10^{-5}$), which is strongly temperature dependent. When heated, the antiferromagnet undergoes a phase transition to the paramagnetic state. The temperature of this transition, at which the magnetic ordering disappears, is called the Neel point (or antiferromagnetic Curie point). Antiferromagnetism is found in chromium, manganese, and a number of rare earth elements. Typical antiferromagnets are simple chemical compounds based on transition group metals such as oxides, halides, sulfides, carbonates, and the like.

Ferromagnets are substances whose magnetic properties are due to uncompensated antiferromagnetism. Similar to ferromagnets, they have a high magnetic susceptibility, which depends significantly on the magnetic field strength and

temperature. At the same time, ferromagnets are characterized by a number of significant differences from ferromagnetic materials. Some ordered metal alloys have ferromagnetic properties, but mainly various oxide compounds, among which ferrites are of the greatest practical interest.

Dia-, para-, and antiferromagnets can be grouped into a group of weakly magnetic substances, while ferro- and ferromagnets are strongly magnetic materials.

All magnetic materials are conventionally divided into magnetically soft and magnetically hard. Magnetically soft materials are those that are easily magnetized by an external magnetic field. Such materials are characterized by low values of coercive force and high values of magnetic permeability. They are used to concentrate a magnetic field. In most cases, magnetically soft materials operate in alternating magnetic fields, so a high resistivity is important for them. Historically, the first magnetically soft material was low-carbon iron, which has low mechanical hardness. Therefore, such materials are called magnetically soft.

Magnetostrictive materials are materials with high coercive force and high residual induction. They are used to make permanent magnets, which are sources of a constant magnetic field. Historically, the first magnetically hard materials were mechanically hard, hardened carbon steels. Therefore, such materials are called magnetostrictive.

5.3. Ferromagnets

According to Ampère's hypothesis, molecular currents flow inside atoms and molecules, and thus magnetic dipoles exist. In fact, Ampère's hypothesis was brilliantly confirmed when the electronic structure of the atom was understood. The movement of electrons around the nuclei of atoms is the elementary currents that create magnetic moments. A more rigorous consideration of elementary magnetic moments shows that an atom has magnetic moments of nuclei, orbital magnetic moments of electrons, and spin magnetic moments of electrons. The magnetic moments of atomic nuclei are negligibly small compared to the magnetic moments of electrons, so their influence on the magnetic properties of materials can be neglected. The orbital magnetic moments of electrons are also much smaller than the spin magnetic moments. Therefore, the magnetic properties of materials are mainly determined by the spin magnetic moments of electrons.

According to Hund's rule, the electron orbitals are filled so that the magnetic and mechanical moments of the electrons are maximized. In transition metals, the internal electron orbitals (3d or 5f) are not completely filled. Therefore, the atoms of such elements have a significant magnetic moment. Exchange interaction can lead to a mutual orientation of the magnetic moments of neighboring atoms. Depending on the orientation of the magnetic moments of neighboring atoms, all substances are divided into ferromagnets, antiferromagnets, and paramagnets.

In order for a substance to be ferromagnetic, two conditions must be met:

1) The material must contain transition metal atoms with large magnetic moments;

2) The ratio of the distance between the atoms to the radius of the unfilled electron shells must exceed 3.

The magnetic moments of neighboring ferromagnetic atoms are oriented in parallel, but in a crystal of sufficiently large size, all magnetic moments cannot be oriented in parallel. Otherwise, a magnetic field will appear around the crystal and the energy of the system will increase. To reduce the energy of the system, the crystal is divided into domains - regions of spontaneous magnetization, and the division is carried out so that there is no external magnetic field.

At the boundaries of the domains, the energy of the atoms is increased. Therefore, in order for the energy of the material to be minimal, it is necessary that the length of the domain boundaries be minimal, or the size of the domain, which is the deformation of the crystal lattice under the influence of a magnetic field. The exchange interaction between atoms leads to the emergence of additional interaction forces and the crystal lattice is deformed. The growth of the domain leads to an increase in the local field strength inside the domain and an increase in lattice deformation. At the same time, the energy of the system increases. Thus, the opposition of magnetic anisotropy and magnetostriction leads to the establishment of the optimal size of magnetic domains.

When a ferromagnet is placed in an external magnetic field, the magnetization vectors of some domains will be the same or close to the same as the vector of the external magnetic field strength. The energy of such domains will be minimal, while the energy of all other domains will increase. The dependence of induction on the external magnetic field strength is called the magnetization curve (fig. 5.1).

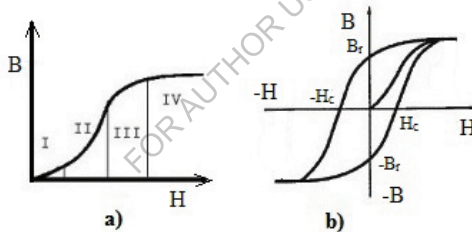

Fig. 5.1. Magnetization curve (a) and hysteresis loop (b).

In the initial part of the magnetization curve, an increase in the external field strength leads to a slight increase in induction, and when the external field is turned off, the induction decreases to zero. This section is called the reverse magnetization section or Rayleigh region (I) (fig. 5.1. a). In the second section, a slight change in the external field strength leads to noticeable changes in induction. This section is called the area of sharp increase in induction or the Barkhausen jump region (II). In the third section of the magnetization curve, the dependence of induction on the external field strength weakens again. This section is called the slow magnetization section or the region of magnetization due to rotation processes (III). In the fourth region, the induction increases in proportion to the magnetic field strength. This region is called the saturation region or the paraprocess region (IV).

When a ferromagnet is exposed to an external magnetic field, the growth of favorably oriented domains begins, i.e., their boundaries shift. However, the structural inhomogeneities of the material prevent the displacement of domain boundaries (i.e.,

they are the points of anchoring the domain boundaries) and the boundaries bend under the influence of an external field.

Bending the boundaries is not energetically beneficial, as it leads to an increase in their surface, so when the external field is turned off, the boundaries are straightened again and the magnetization disappears. Thus, at low values of the external field intensity, a reverse magnetization region or Rayleigh region is realized. With a further increase in the external field strength, the bending of the boundaries becomes so large that the energy of the bent boundaries coincides with the energy of the boundaries that have detached from the anchoring points. Further bending of the boundaries becomes energetically disadvantageous, the boundaries are detached from the anchoring points and move in jumps to the next row of anchoring points. At the same time, a region of sharp increase in induction or a region of Barkhausen jumps is observed.

Once the domain boundaries are displaced, the favorably oriented domains fill the entire volume of the crystal, and the magnetization begins to increase due to the rotation of the magnetic moments of the atoms from the direction of light magnetization to the direction of heavy magnetization. Since the rotation of magnetic moments is not energetically advantageous, it requires a high external field strength. Thus, a slow magnetization area or a magnetization region due to rotation processes is realized. When all the magnetic moments of the atoms are directed by the external field, there will be no increase in magnetization, and the increase in induction occurs due to an increase in the magnetic field strength, as in paramagnets. A saturation zone or paraprocess region is observed.

If, after magnetizing the ferromagnet to saturation, the external magnetic field is turned off, the magnetization of the ferromagnet is not completely removed and the residual induction B_r is retained (fig. 5.1, b). This is due to the fact that structural defects that prevent the movement of domain boundaries during magnetization prevent the reverse displacement of domain boundaries during demagnetization. To remove the residual induction, it is necessary to apply a field of reverse polarity. At a certain value of the field strength, which is called the coercive force H_c , the induction will disappear. A further increase in the field strength in the opposite direction will lead to magnetization of the ferromagnet. Naturally, the sign of the magnetic induction vector will change. Turning off the external magnetic field will again lead to the appearance of residual induction, which must be removed by applying a coercive force. Thus, when a ferromagnet is placed in an alternating magnetic field, a hysteresis loop appears (fig. 5.1.b). The more structural defects and grain boundaries in the material that make it difficult to move, the higher the coercive force and the wider the hysteresis loop.

5.4. Magnetically soft materials

Common magnetically soft materials are iron and its alloys with silicon. They are used to operate magnetic cores in DC and low-frequency fields. The cheapest material is technically pure iron with a total impurity content of up to 0.1%. Due to its relatively low electrical resistivity ($0.1 \mu\Omega\cdot\text{m}$), pure iron is mainly used for magnetic cores of constant magnetic flux. A significant disadvantage of technically pure iron is its aging, i.e., an increase in coercive force over time due to the release of finely dispersed carbide and nitride particles.

The purification of iron from impurities leads to an increase in magnetic permeability and a decrease in coercive force. These advantages are particularly pronounced in weak fields, i.e. in fields used in electronics and measuring devices. Depending on the technology of iron purification, electrolytic, reduced and carbonyl iron are distinguished. Since purification significantly increases the cost of the material, its use is extremely limited. Carbonyl iron is the most widely used. This is due to the fact that the decomposition of iron pentacarbonyl produces a metal powder. By mixing this powder with a varnish, a material can be obtained that combines high resistivity with high magnetic permeability.

The low electrical resistance of iron leads to high eddy current losses in alternating fields and reduced magnetic permeability. When iron is alloyed with silicon, the resistivity increases significantly. For example, in an alloy containing 5% silicon, the resistivity reaches $0.7 \mu\Omega\cdot\text{m}$, i.e., it increases more than 7 times compared to pure iron. In addition, the presence of silicon in iron reduces magnetic anisotropy and magnetostriction. It is important to note that the interaction of silicon with dislocations leads to a decrease in the mobility of the latter, which reduces the ductility of alloys. In this regard, industrial iron-silicon alloys, such as electrical steels, contain no more than 5% Si.

Since electrical steels retain magnetic anisotropy, textured steel, i.e., steel with some crystallographic directions in neighboring grains that coincide, is used to improve magnetic properties. To obtain steel with high magnetic permeability and low losses, a coincidence of directions of the type [111] is required. In order to obtain a magnetic texture, cold rolling with large compression and subsequent annealing at a temperature of 900-1000°C is used.

For materials operating in weak fields, a high value of the initial magnetic permeability is of utmost importance. In other words, high mobility of domain boundaries under conditions of low external magnetic field strength is important for such materials. Consequently, such materials should be single-phase and have low magnetic anisotropy and magnetostriction. To achieve maximum magnetic permeability, heavily alloyed alloys are used. Examples include alsifer and permalloy.

Alsifer is an alloy of the Fe – Si - Al system containing about 9.5% silicon and 5.5% aluminum. With this composition, magnetic anisotropy is minimal and the alloy has a very high magnetic permeability. The alloy has a fairly high electrical resistivity ($\rho = 0.81 \mu\Omega\cdot\text{m}$), which reduces eddy current losses. At the same time, the alloy is non-plastic and hard. Parts made of it are produced by powder metallurgy, and the final processing of parts is possible only by anode-mechanical and electric spark methods, as well as by grinding. The complexity of processing increases the cost of products, but since the alloy does not contain expensive components, it is widely used for the manufacture of magnetic screens and magnetic cores.

An alloy of iron and nickel is called permalloy. A distinction is made between low-nickel permalloy and high-nickel permalloy. Low-nickel permalloy contains 45-65% Ni, while high-nickel permalloy contains 76-80% Ni. Low-nickel permalloys are characterized by a higher resistivity and increased saturation induction, however, the magnetic permeability of low-nickel permalloy is lower than that of high-nickel permalloy.

In high-frequency fields, eddy current losses increase dramatically. Therefore, materials with a high resistivity are used in high-frequency fields, such as magnetodielectrics, ferromagnets with an amorphous structure, and ferrites.

Magnetodielectrics are produced by mixing powdered ferromagnets and an organic or inorganic binder. Carbonyl iron, alsiifer, or molybdenum permalloy, additionally doped with sulfur, is used as a ferromagnet. Sulfur is added to permalloy to make it brittle. Ferromagnets with an amorphous structure are obtained by ultra-fast cooling of the melt, with cooling rates reaching 10^6 to 10^8 degrees per second. With such rapid cooling, the crystal lattice does not have time to form, and the material is a supercooled liquid. The absence of a crystal lattice leads to complete isotropy of magnetic properties, and in the absence of magnetic anisotropy, the mobility of domain boundaries becomes high. Thus, materials with an amorphous structure are magnetically soft.

Ferrites are ionic compounds of the MeOF_2O_3 type, which are chemical salts of the acid MeFe_2O_4 , where Me is a cation of any divalent metal or two cations of a monovalent metal. Most ferrites have a symmetrical cubic crystal lattice. Nickel-zinc, lithium-zinc, and manganese-zinc ferrites are the most widely used magnetically soft materials.

According to their electrical properties, ferrites are semiconductors or dielectrics, so the losses due to eddy currents in ferrites are negligible. In addition, they have a high dielectric constant, which leads to a decrease in the propagation speed of electromagnetic waves in ferrites. This circumstance makes it possible to manufacture delay lines, magnetic valves, etc. on the basis of ferrites. Single crystals of magnetically soft ferrites are used to manufacture magnetic heads for recording and reproducing audio and video signals in tape recorders.

5.5. Magnetically hard materials

Magnetically hard materials are used to manufacture permanent magnets, the stored magnetic energy of which is estimated as the product of residual induction and coercive force

$$E_{mag} = H_c B_r . \quad (5.2)$$

In order to increase the coercive force, it is necessary to make it difficult for the domain boundaries to move. To do this, the magnetic anisotropy should be maximized, the grain size should be minimal, and the material should contain particles that prevent the movement of domain boundaries.

Magnetically hard materials are carbon steels hardened to martensite. This results in a structure that is ideal from the point of view of magnetically hard materials - a dispersed mixture of ferromagnetic and nonferromagnetic phases, with the ferromagnetic phase having a large magnetic anisotropy. However, the properties of martensitic hardened steels are far from ideal, the reason being that a large volume of hardened steels is occupied by the nonferromagnetic phase, austenite, so their magnetization and, consequently, residual induction are low. Another disadvantage of martensitic steels is their low hardenability, which is the ability to withstand hardening to a considerable depth, preventing martensitic transformation in the deeper layers of the material. To increase the hardenability, steels are additionally alloyed with

chromium, tungsten, molybdenum and cobalt. Alloying steels with cobalt is particularly effective because cobalt atoms have a magnetic moment and residual induction increases in the presence of cobalt.

Magnetically hard materials are non-ductile, since dispersed particles of the emissions that prevent the displacement of domain boundaries impede the movement of dislocations. However, in some cases, it is necessary to have magnetically hard material in the form of tapes, sheets, wires for the manufacture of stamping elements of measuring systems, compass and bead hands, magnetic recording tapes, and so on. Such materials should have a noticeable plasticity.

Magnetically deformable materials include alloys of the Cu-20% Ni-20% Fe-cunife, Cu-20% Ni-20% Co-cunico, and Fe-52% Co-(4-14)%V-vicaloy systems. In copper-based alloys, a large coercive force occurs after significant compression and subsequent tempering at 600 oC. The high magnetic properties of these materials are due to the release of single-domain particles of the ferromagnetic phase during the cooling of the supersaturated solid solution. It is important to note that during the preliminary deformation, a sharp texture appears in the material, so the released particles are oriented. Alloys of the Co - V - Fe system are characterized by high induction (up to 1.8 T). They are used to make small magnets, compass and bead hands, and magnetic wire.

The most famous of the magnetically hard ferrites is barium ferrite $\text{BaO}_6\text{Fe}_2\text{O}_3$ (FB, ferroxdur). Unlike magnetically soft ferrites, it has a hexagonal lattice with uniaxial anisotropy rather than a cubic lattice. The high coercive force is due to its small grain size and strong crystallographic anisotropy. In addition to barium ferrite, chromium-barium ferrite (CB) and cobalt ferrite are used. Ferritic materials are much cheaper than metal materials. At the same time, they have a significantly lower specific gravity. The high coercive force makes it possible to produce magnets with a small length-to-section ratio.

The disadvantages of magnetically hard ferrite include low mechanical strength, brittleness, and high sensitivity to temperature changes.

Appendix

Table 1. Properties of Ge, Si, GaAs (at 300 K).

Properties	Ge	Si	GaAs
1	2	3	4
Number of atoms in 1 cm ³	4,42 · 10 ²²	5,0 · 10 ²²	2,21 · 10 ²²
Atomic mass	72,6	28,08	144,63
Breakdown field, V/cm	~10 ⁵	~3 · 10 ⁵	~4 · 10 ⁵
Crystal structure	Diamond	Diamond	Zinc deceptions
Density, g/cm ³	5,3267	2,328	5,32
Relative dielectric constant permeability	16	11,8	10,9
Effective density of states in the conduction band N _c , cm ⁻³	1,04 · 10 ¹⁹	2,8 · 10 ¹⁹	4,7 · 10 ¹⁷
Effective density of states in the valence band N _v , cm ⁻³	6,1 · 10 ¹⁸	1,02 · 10 ¹⁹	7,0 · 10 ¹⁸
Effective masses m*:			
electrons	0,22m _e	1,06 m _e	0,07 m _e
holes	0,39m _e	0,56 m _e	0,5 m _e
Affinity for electron, eV	4,0	4,05	4,07
Band gap at 300 K, eV	0,66	1,11	1,43
Intrinsic concentration, cm ⁻³	2,5 · 10 ¹³	1,6 · 10 ¹⁰	1,1 · 10 ⁷
Grating constant, nm	0,565748	0,543086	0,56534
Temperature coefficient of linear expansion of linear expansion ΔL/LΔT, °C ⁻¹	5,8 · 10 ⁻⁶	2,6 · 10 ⁻⁶	5,9 · 10 ⁻⁶
Melting point, °C	937	1420	1238
Lifetime of non-basic media, s	10 ⁻³	2,5 · 10 ⁻³	10 ⁻⁸
Mobility is drift cm ² /(V·s) :			
electrons μ _n	3900	1500	8500
holes μ _p	1900	600	400

Continuation of Table 1

Properties	Ge	Si	G a A s
1	2	3	4
Energy of Raman phonons E_r , eV	0,037	0,063	0,035
Specific heat, J/(g·°C)	0,31	0,7	0,35
Thermal conductivity (at 300 K), W/(cm·°C)	0,64	1,45	0,46
Thermal diffusion coefficient, cm ² /s	0,36	0,9	0,44
Steam pressure, Pa	0,133 at 1270°C $1,33 \cdot 10^{-6}$ at 800 °C	0,133 at 1600 °C $1,33 \cdot 10^{-6}$ at 930 °C	$1,01 \cdot 10^5$ at 1050°C $1,01 \cdot 10^7$ at 1220 °C
Output work, eV	4,4	4,8	4,7

Table 2.

Dependence of the EMF of a differential chromel-copper (Тип L) thermocouple on the temperature of the working junction (calibration table).

Temperature range from -20 °C ° to +200 °C

t, °C	0	1	2	3	4	5	6	7	8	9
	ЭДС, мВ									
-20	-1,27	-1,35	-1,39	-1,46	-1,52	-1,58	-1,64	-1,70	-1,77	-1,83
-10	-0,64	-0,70	-0,77	-0,83	-0,89	-0,96	-1,02	-1,08	-1,14	-1,21
-0	0	-0,06	-0,13	-0,19	0,26	-0,32	-0,38	0,45	-0,51	-0,58
+0	0	0,07	0,13	0,20	0,26	0,33	0,39	0,46	0,52	0,59
10	0,65	0,72	0,78	0,85	0,91	0,98	1,05	1,11	1,18	1,24
20	1,31	1,38	1,44	1,51	1,57	1,64	1,70	1,77	1,84	1,91
30	1,98	2,05	2,12	2,18	2,25	2,32	2,38	2,45	2,52	2,59
40	2,66	2,73	2,80	2,87	2,94	3,00	3,07	3,14	3,21	3,28
50	3,35	3,42	3,49	3,56	3,63	3,70	3,77	3,84	3,91	3,98
60	4,05	4,12	4,19	4,26	4,33	4,41	4,48	4,55	4,62	4,69
70	4,76	4,83	4,90	4,98	5,05	5,12	5,20	5,27	5,34	5,41
80	5,48	5,56	5,63	5,70	5,78	5,85	5,92	5,99	6,07	6,14
90	6,21	6,29	6,36	6,43	6,51	6,58	6,65	6,73	6,80	6,87
100	6,95	7,03	7,10	7,17	7,25	7,32	7,40	7,47	7,54	7,62
110	7,69	7,77	7,84	7,91	7,99	8,06	8,13	8,21	8,28	8,35
120	8,43	8,50	8,58	8,65	8,73	8,80	8,88	8,95	9,03	9,10
130	9,18	9,25	9,33	9,40	9,48	9,55	9,63	9,70	9,78	9,85
140	9,93	10,00	10,08	10,16	10,23	10,31	10,38	10,46	10,54	10,61
150	10,69	10,77	10,85	10,92	11,00	11,08	11,15	11,23	11,31	11,38
160	11,46	11,54	11,62	11,69	11,77	11,85	11,93	12,00	12,08	12,16
170	12,24	12,32	12,40	12,48	12,55	12,63	12,71	12,79	12,87	12,93
180	13,03	13,11	13,19	13,27	13,36	13,44	13,52	13,60	13,68	13,76
190	13,84	13,92	14,00	14,08	14,16	14,23	14,33	14,42	14,50	14,58
200	14,66	14,74	14,82	14,90	14,98	15,06	15,14	15,22	15,30	15,38

Table 3.

Dependence of the EMF of a differential chromel-alumel (**Type K**) thermocouple on the temperature of the working junction (calibration table).
Temperature range from -270 °C to 1370 °C.

-270	-6.458											
-280	-6.411	-6.444	-6.446	-6.448	-6.450	-6.452	-6.453	-6.455	-6.456	-6.457	-6.458	
-250	-6.404	-6.408	-6.413	-6.417	-6.421	-6.425	-6.429	-6.432	-6.435	-6.438	-6.441	
-240	-6.344	-6.351	-6.358	-6.364	-6.370	-6.377	-6.382	-6.388	-6.393	-6.399	-6.404	
-230	-6.262	-6.271	-6.280	-6.289	-6.297	-6.306	-6.314	-6.322	-6.329	-6.337	-6.344	
-220	-6.158	-6.170	-6.181	-6.192	-6.202	-6.213	-6.223	-6.233	-6.243	-6.252	-6.262	
-210	-6.035	-6.048	-6.061	-6.074	-6.087	-6.099	-6.111	-6.123	-6.135	-6.147	-6.158	
-200	-5.891	-5.907	-5.922	-5.936	-5.951	-5.965	-5.980	-5.994	-6.007	-6.021	-6.035	
-190	-5.730	-5.747	-5.763	-5.780	-5.797	-5.813	-5.829	-5.845	-5.861	-5.876	-5.891	
-180	-5.550	-5.569	-5.588	-5.606	-5.624	-5.642	-5.660	-5.678	-5.695	-5.713	-5.730	
-170	-5.354	-5.374	-5.395	-5.415	-5.435	-5.454	-5.474	-5.493	-5.512	-5.531	-5.550	
-160	-5.141	-5.163	-5.185	-5.207	-5.228	-5.250	-5.271	-5.292	-5.313	-5.333	-5.354	
-150	-4.913	-4.936	-4.960	-4.983	-5.006	-5.029	-5.052	-5.074	-5.097	-5.119	-5.141	
-140	-4.669	-4.694	-4.719	-4.744	-4.768	-4.793	-4.817	-4.841	-4.865	-4.889	-4.913	
-130	-4.411	-4.437	-4.463	-4.490	-4.516	-4.542	-4.567	-4.593	-4.618	-4.644	-4.669	
-120	-4.138	-4.166	-4.194	-4.221	-4.249	-4.276	-4.303	-4.330	-4.357	-4.384	-4.411	
-110	-3.852	-3.882	-3.911	-3.939	-3.968	-3.997	-4.025	-4.054	-4.082	-4.110	-4.138	
-100	-3.554	-3.584	-3.614	-3.645	-3.675	-3.705	-3.734	-3.764	-3.794	-3.823	-3.852	
-90	-3.243	-3.274	-3.306	-3.337	-3.368	-3.400	-3.431	-3.462	-3.492	-3.523	-3.554	
-80	-2.920	-2.953	-2.986	-3.018	-3.050	-3.083	-3.115	-3.147	-3.179	-3.211	-3.243	
-70	-2.587	-2.620	-2.654	-2.688	-2.721	-2.755	-2.788	-2.821	-2.854	-2.887	-2.920	
-60	-2.243	-2.278	-2.312	-2.347	-2.382	-2.416	-2.450	-2.485	-2.519	-2.553	-2.587	
-50	-1.889	-1.925	-1.961	-1.996	-2.032	-2.067	-2.103	-2.138	-2.173	-2.208	-2.243	
-40	-1.527	-1.564	-1.600	-1.637	-1.673	-1.709	-1.745	-1.782	-1.818	-1.854	-1.889	
-30	-1.156	-1.194	-1.231	-1.268	-1.305	-1.343	-1.380	-1.417	-1.453	-1.490	-1.527	
-20	-0.778	-0.816	-0.854	-0.892	-0.930	-0.968	-1.006	-1.043	-1.081	-1.119	-1.156	
-10	-0.392	-0.431	-0.470	-0.508	-0.547	-0.586	-0.624	-0.663	-0.701	-0.739	-0.778	
0	0.000	-0.039	-0.079	-0.118	-0.157	-0.197	-0.236	-0.275	-0.314	-0.353	-0.392	
0	0.000	0.039	0.079	0.119	0.158	0.198	0.238	0.277	0.317	0.357	0.397	
10	0.397	0.437	0.477	0.517	0.557	0.597	0.637	0.677	0.718	0.758	0.798	
20	0.798	0.838	0.879	0.919	0.960	1.000	1.041	1.081	1.122	1.163	1.203	
30	1.203	1.244	1.285	1.326	1.366	1.407	1.448	1.489	1.530	1.571	1.612	
40	1.612	1.653	1.694	1.735	1.776	1.817	1.858	1.899	1.941	1.982	2.023	
50	2.023	2.064	2.106	2.147	2.188	2.230	2.271	2.312	2.354	2.395	2.436	
60	2.436	2.478	2.519	2.561	2.602	2.644	2.685	2.727	2.768	2.810	2.851	
70	2.851	2.893	2.934	2.976	3.017	3.059	3.100	3.142	3.184	3.225	3.267	
80	3.267	3.308	3.350	3.391	3.433	3.474	3.516	3.557	3.599	3.640	3.682	
90	3.682	3.723	3.765	3.806	3.848	3.889	3.931	3.972	4.013	4.055	4.096	
100	4.096	4.138	4.179	4.220	4.262	4.303	4.344	4.385	4.427	4.468	4.509	
110	4.509	4.550	4.591	4.633	4.674	4.715	4.756	4.797	4.838	4.879	4.920	
120	4.920	4.961	5.002	5.043	5.084	5.124	5.165	5.206	5.247	5.288	5.328	
130	5.328	5.369	5.410	5.450	5.491	5.532	5.572	5.613	5.653	5.694	5.735	
140	5.735	5.775	5.815	5.856	5.896	5.937	5.977	6.017	6.058	6.098	6.138	
150	6.138	6.179	6.219	6.259	6.299	6.339	6.380	6.420	6.460	6.500	6.540	
160	6.540	6.580	6.620	6.660	6.701	6.741	6.781	6.821	6.861	6.901	6.941	
170	6.941	6.981	7.021	7.060	7.100	7.140	7.180	7.220	7.260	7.300	7.340	
180	7.340	7.380	7.420	7.460	7.500	7.540	7.579	7.619	7.659	7.699	7.739	
190	7.739	7.779	7.819	7.859	7.899	7.939	7.979	8.019	8.059	8.099	8.138	

Continuation of Table 3

200	8.138	8.178	8.218	8.258	8.298	8.338	8.378	8.418	8.458	8.499	8.539	200
210	8.539	8.579	8.619	8.659	8.699	8.739	8.779	8.819	8.860	8.900	8.940	210
220	8.940	8.980	9.020	9.061	9.101	9.141	9.181	9.222	9.262	9.302	9.343	220
230	9.343	9.383	9.423	9.464	9.504	9.545	9.585	9.626	9.666	9.707	9.747	230
240	9.747	9.788	9.828	9.869	9.909	9.950	9.991	10.031	10.072	10.113	10.153	240
250	10.153	10.194	10.235	10.276	10.316	10.357	10.398	10.439	10.480	10.520	10.561	250
260	10.561	10.602	10.643	10.684	10.725	10.766	10.807	10.848	10.889	10.930	10.971	260
270	10.971	11.012	11.053	11.094	11.135	11.176	11.217	11.259	11.300	11.341	11.382	270
280	11.382	11.423	11.465	11.506	11.547	11.588	11.630	11.671	11.712	11.753	11.795	280
290	11.795	11.836	11.877	11.919	11.960	12.001	12.043	12.084	12.126	12.167	12.209	290
300	12.209	12.250	12.291	12.333	12.374	12.416	12.457	12.499	12.540	12.582	12.624	300
310	12.624	12.665	12.707	12.748	12.790	12.831	12.873	12.915	12.956	12.998	13.040	310
320	13.040	13.081	13.123	13.165	13.206	13.248	13.290	13.331	13.373	13.415	13.457	320
330	13.457	13.498	13.540	13.582	13.624	13.665	13.707	13.749	13.791	13.833	13.874	330
340	13.874	13.916	13.958	14.000	14.042	14.084	14.126	14.167	14.209	14.251	14.293	340
350	14.293	14.335	14.377	14.419	14.461	14.503	14.545	14.587	14.629	14.671	14.713	350
360	14.713	14.755	14.797	14.839	14.881	14.923	14.965	15.007	15.049	15.091	15.133	360
370	15.133	15.175	15.217	15.259	15.301	15.343	15.385	15.427	15.469	15.511	15.554	370
380	15.554	15.596	15.638	15.680	15.722	15.764	15.806	15.849	15.891	15.933	15.975	380
390	15.975	16.017	16.059	16.102	16.144	16.186	16.228	16.270	16.313	16.355	16.397	390
400	16.397	16.439	16.482	16.524	16.566	16.608	16.651	16.693	16.735	16.778	16.820	400
410	16.820	16.862	16.904	16.947	16.989	17.031	17.074	17.116	17.158	17.201	17.243	410
420	17.243	17.285	17.328	17.370	17.413	17.455	17.497	17.540	17.582	17.624	17.667	420
430	17.667	17.709	17.752	17.794	17.837	17.879	17.921	17.964	18.006	18.049	18.091	430
440	18.091	18.134	18.176	18.218	18.261	18.303	18.346	18.388	18.431	18.473	18.516	440
450	18.516	18.558	18.601	18.643	18.686	18.728	18.771	18.813	18.856	18.898	18.941	450
460	18.941	18.983	19.026	19.068	19.111	19.154	19.196	19.239	19.281	19.324	19.366	460
470	19.366	19.409	19.451	19.494	19.537	19.579	19.622	19.664	19.707	19.750	19.792	470
480	19.792	19.835	19.877	19.920	19.962	20.005	20.048	20.090	20.133	20.175	20.218	480
490	20.218	20.261	20.303	20.346	20.389	20.431	20.474	20.516	20.559	20.602	20.644	490
500	20.644	20.687	20.730	20.772	20.815	20.857	20.900	20.943	20.985	21.028	21.071	500
510	21.071	21.113	21.156	21.199	21.241	21.284	21.326	21.369	21.412	21.454	21.497	510
520	21.497	21.540	21.582	21.625	21.668	21.710	21.753	21.796	21.838	21.881	21.924	520
530	21.924	21.966	22.009	22.052	22.094	22.137	22.179	22.222	22.265	22.307	22.350	530
540	22.350	22.393	22.435	22.478	22.521	22.563	22.606	22.649	22.691	22.734	22.776	540
550	22.776	22.819	22.862	22.904	22.947	22.990	23.032	23.075	23.117	23.160	23.203	550
560	23.203	23.245	23.288	23.331	23.373	23.416	23.458	23.501	23.544	23.586	23.629	560
570	23.629	23.671	23.714	23.757	23.799	23.842	23.884	23.927	23.970	24.012	24.055	570
580	24.055	24.097	24.140	24.182	24.225	24.267	24.310	24.353	24.395	24.438	24.480	580
590	24.480	24.523	24.565	24.608	24.650	24.693	24.735	24.778	24.820	24.863	24.905	590
600	24.905	24.948	24.990	25.033	25.075	25.118	25.160	25.203	25.245	25.288	25.330	600
610	25.330	25.373	25.415	25.458	25.500	25.543	25.585	25.627	25.670	25.712	25.755	610
620	25.755	25.797	25.840	25.882	25.924	25.967	26.009	26.052	26.094	26.136	26.179	620
630	26.179	26.221	26.263	26.306	26.348	26.390	26.433	26.475	26.517	26.560	26.602	630
640	26.602	26.644	26.687	26.729	26.771	26.814	26.856	26.898	26.940	26.983	27.025	640
650	27.025	27.067	27.109	27.152	27.194	27.236	27.278	27.320	27.363	27.405	27.447	650
660	27.447	27.489	27.531	27.574	27.616	27.658	27.700	27.742	27.784	27.826	27.869	660
670	27.869	27.911	27.953	27.995	28.037	28.079	28.121	28.163	28.205	28.247	28.289	670
680	28.289	28.332	28.374	28.416	28.458	28.500	28.542	28.584	28.626	28.668	28.710	680
690	28.710	28.752	28.794	28.835	28.877	28.919	28.961	29.003	29.045	29.087	29.129	690

Continuation of Table 3

700	29.129	29.171	29.213	29.255	29.297	29.338	29.380	29.422	29.464	29.506	29.548
710	29.548	29.589	29.631	29.673	29.715	29.757	29.798	29.840	29.882	29.924	29.965
720	29.985	30.007	30.049	30.090	30.132	30.174	30.216	30.257	30.299	30.341	30.382
730	30.382	30.424	30.466	30.507	30.549	30.590	30.632	30.674	30.715	30.757	30.798
740	30.798	30.840	30.881	30.923	30.964	31.006	31.047	31.089	31.130	31.172	31.213
750	31.213	31.255	31.296	31.338	31.379	31.421	31.462	31.504	31.545	31.586	31.628
760	31.628	31.669	31.710	31.752	31.793	31.834	31.876	31.917	31.958	32.000	32.041
770	32.041	32.082	32.124	32.165	32.206	32.247	32.289	32.330	32.371	32.412	32.453
780	32.453	32.495	32.536	32.577	32.618	32.659	32.700	32.742	32.783	32.824	32.865
790	32.865	32.906	32.947	32.988	33.029	33.070	33.111	33.152	33.193	33.234	33.275
800	33.275	33.316	33.357	33.398	33.439	33.480	33.521	33.562	33.603	33.644	33.685
810	33.685	33.726	33.767	33.808	33.848	33.889	33.930	33.971	34.012	34.053	34.093
820	34.093	34.134	34.175	34.216	34.257	34.297	34.338	34.379	34.420	34.460	34.501
830	34.501	34.542	34.582	34.623	34.664	34.704	34.745	34.785	34.826	34.867	34.908
840	34.908	34.948	34.989	35.029	35.070	35.110	35.151	35.192	35.232	35.273	35.313
850	35.313	35.354	35.394	35.435	35.475	35.516	35.556	35.596	35.637	35.677	35.718
860	35.718	35.758	35.798	35.839	35.879	35.920	35.960	36.000	36.041	36.081	36.121
870	36.121	36.162	36.202	36.242	36.282	36.323	36.363	36.403	36.443	36.484	36.524
880	36.524	36.564	36.604	36.644	36.685	36.725	36.765	36.805	36.845	36.885	36.925
890	36.925	36.965	37.006	37.046	37.086	37.126	37.166	37.206	37.246	37.286	37.326
900	37.326	37.366	37.406	37.446	37.486	37.526	37.566	37.606	37.646	37.686	37.725
910	37.725	37.765	37.805	37.845	37.885	37.925	37.965	38.005	38.044	38.084	38.124
920	38.124	38.164	38.204	38.243	38.283	38.323	38.363	38.402	38.442	38.482	38.522
930	38.522	38.561	38.601	38.641	38.680	38.720	38.760	38.799	38.839	38.878	38.918
940	38.918	38.958	38.997	39.037	39.076	39.116	39.155	39.195	39.235	39.274	39.314
950	39.314	39.353	39.393	39.432	39.471	39.511	39.550	39.590	39.629	39.668	39.708
960	39.708	39.747	39.787	39.826	39.866	39.905	39.944	39.984	40.023	40.062	40.101
970	40.101	40.141	40.180	40.219	40.259	40.298	40.337	40.376	40.415	40.455	40.494
980	40.494	40.533	40.572	40.611	40.651	40.690	40.729	40.768	40.807	40.846	40.885
990	40.885	40.924	40.963	41.002	41.042	41.081	41.120	41.159	41.198	41.237	41.276
1000	41.276	41.315	41.354	41.393	41.431	41.470	41.509	41.548	41.587	41.626	41.665
1010	41.665	41.704	41.743	41.781	41.820	41.859	41.898	41.937	41.976	42.014	42.053
1020	42.053	42.092	42.131	42.169	42.208	42.247	42.286	42.324	42.363	42.402	42.440
1030	42.440	42.479	42.518	42.556	42.595	42.633	42.672	42.711	42.749	42.788	42.826
1040	42.826	42.865	42.903	42.942	42.980	43.019	43.057	43.096	43.134	43.173	43.211
1050	43.211	43.250	43.288	43.327	43.365	43.403	43.442	43.480	43.518	43.557	43.595
1060	43.595	43.633	43.672	43.710	43.748	43.787	43.825	43.863	43.901	43.940	43.978
1070	43.978	44.016	44.054	44.092	44.130	44.169	44.207	44.245	44.283	44.321	44.359
1080	44.359	44.397	44.435	44.473	44.512	44.550	44.588	44.626	44.664	44.702	44.740
1090	44.740	44.778	44.816	44.853	44.891	44.929	44.967	45.005	45.043	45.081	45.119
1100	45.119	45.157	45.194	45.232	45.270	45.308	45.346	45.383	45.421	45.459	45.497
1110	45.497	45.534	45.572	45.610	45.647	45.686	45.723	45.760	45.798	45.836	45.873
1120	45.873	45.911	45.948	45.986	46.024	46.061	46.099	46.136	46.174	46.211	46.249
1130	46.249	46.286	46.324	46.361	46.398	46.436	46.473	46.511	46.548	46.585	46.623
1140	46.623	46.660	46.697	46.735	46.772	46.809	46.847	46.884	46.921	46.958	46.995
1150	46.995	47.033	47.070	47.107	47.144	47.181	47.218	47.256	47.293	47.330	47.367
1160	47.367	47.404	47.441	47.478	47.515	47.552	47.589	47.626	47.663	47.700	47.737
1170	47.737	47.774	47.811	47.848	47.884	47.921	47.958	47.995	48.032	48.069	48.105
1180	48.105	48.142	48.179	48.216	48.252	48.289	48.326	48.363	48.399	48.436	48.473
1190	48.473	48.509	48.546	48.582	48.619	48.656	48.692	48.729	48.765	48.802	48.838
1200	48.838	48.875	48.911	48.948	48.984	49.021	49.057	49.093	49.130	49.166	49.202
1210	49.202	49.239	49.275	49.311	49.348	49.384	49.420	49.456	49.493	49.529	49.565
1220	49.565	49.601	49.637	49.674	49.710	49.746	49.782	49.818	49.854	49.890	49.925
1230	49.926	49.962	49.998	50.034	50.070	50.106	50.142	50.178	50.214	50.250	50.286
1240	50.286	50.322	50.358	50.393	50.429	50.465	50.501	50.537	50.572	50.608	50.644
1250	50.644	50.680	50.715	50.751	50.787	50.822	50.858	50.894	50.929	50.965	51.000
1260	51.000	51.036	51.071	51.107	51.142	51.178	51.213	51.249	51.284	51.320	51.355
1270	51.355	51.391	51.426	51.461	51.497	51.532	51.567	51.603	51.638	51.673	51.708
1280	51.708	51.744	51.779	51.814	51.849	51.885	51.920	51.955	51.990	52.025	52.060
1290	52.060	52.095	52.130	52.165	52.200	52.235	52.270	52.305	52.340	52.375	52.410
1300	52.410	52.445	52.480	52.515	52.550	52.585	52.620	52.654	52.689	52.724	52.759
1310	52.759	52.794	52.828	52.863	52.898	52.932	52.967	53.002	53.037	53.071	53.106
1320	53.106	53.140	53.175	53.210	53.244	53.279	53.313	53.348	53.382	53.417	53.451
1330	53.451	53.486	53.520	53.555	53.589	53.623	53.658	53.692	53.727	53.761	53.795
1340	53.795	53.830	53.864	53.898	53.932	53.967	54.001	54.035	54.069	54.104	54.138
1350	54.138	54.172	54.206	54.240	54.274	54.308	54.343	54.377	54.411	54.445	54.479
1360	54.479	54.513	54.547	54.581	54.615	54.649	54.683	54.717	54.751	54.785	54.819
1370	54.819	54.852	54.886								1370

Bibliography

1. R.K. Rajput. A Textbook of Electrical Engineering Materials. Firewall Media, 2004, 449 p.
2. Ian Jones. Materials Science for Electrical and Electronic Engineers Paperback. Oxford University Press; 6th edition (January 1, 2007) 360 p.. ISBN-10 : 9780195691634
3. Gorbachuk MT. Electrotechnical materials. Tutorial. (UA). LAP LAMBERT Academic Publishing, 17 Meldrum Street, Beau Bassin 71504, Mauritius, 2017. ISBN: 978-620-2-05432-4, 110 c.
4. Vasylenko I.I., Shirokov V.V., Vasylenko Yu.I. Structural and electrical materials. Study guide. - Lviv: Magnolia, 2008 – 242 p.
5. Gorbachuk, M.Larionov, A.Firsov, N.Shatil. Semiconductor Sensors for a Wide Temperature Range. Sensors & Transducers Journal and Magazine, Vol. 162, Issue 1, January 2014, pp.1-4
6. S.A.Mulenko, N.T.Gobachuk. Synthesis of nanometric iron oxide films by RPLD and LCVD for thermo-photo sensors. Applied Physics B: Lasers and Optics, v.105, #3, p.517-523, 2011
7. Gorbachuk N.T., Mitin V.V., Tkhorik Yu.A., Shvarts Yu.M. Piezo-Hall effect in p-germanium. Phys. Stat. Sol.(c) 100. 1980, p.309
8. Gorbachuk N.T., Mitin V.V., Tkhorik Yu.A., Shvarts Yu.M. On determining the deformation potential constants of semiconductors of the p-germanium type from the temperature dependence of the piezoresistance. FTP, vol. 15, v. 14,p.649, 1981
9. Belyakov V.A., Gorbachuk N.T., Didenko P.I. etc. Semiconductor measuring transducers of deformation, temperature and magnetic field for use in conditions of radiation exposure, a wide range of temperatures and magnetic fields. Issues of atomic science and technology, Series: Electrophysical equipment, v.3(29), 2005, p.46-5.
10. Didenko P.I., Gorbachuk N.T. The influence of neutron irradiation on the characteristics of semiconductor measuring transducers of temperature, strain, and magnetic field. Surface, 2005, 4, pp.57-58.
11. M.T. Gorbachuk, A.P. Klimenko. Physical foundations of advanced technologies. /Synopsis of lectures/. Kyiv, DALPU, 1999, 39p.
12. M.T. Gorbachuk, A.P. Klimenko, M.T. Stepashko, L.M. Khanat. Theoretical foundations of advanced technologies. /Synopsis of lectures/. Kyiv, DALPU, 1997, 44p.

TABLE OF CONTENTS

Introduction. Electrotechnical materials - current state, development prospects	1
Chapter 1. General information about electrical materials	2
1.1. Classification of electrical materials.....	2
1.2. Types of chemical bonds. in substances	3
1.3. Crystals. The structure of the crystal lattice. Miller indices	6
1.4. Difference between ideal and real crystals. Lattice vibrations and crystal defects.....	8
1.5. The structure of energy zones	8
1.6. Brillouin and reduced zones.....	11
1.7. Effective mass, electrons and holes	12
1.8. Structure of silicon energy bands.....	13
Chapter 2. Conductors. Electrophysical properties of conductors	16
2.1. General information.....	16
2.2. Electrical conductivity of metals.....	16
2.3. Temperature dependence of the electrical resistance of metals.....	19
2.4. Thin metal films. Dimensional effects.....	21
2.5. Contact phenomena. Thermo EMF	22
2.6. Materials with high conductivity	24
2.7. Superconductors.....	28
2.8. Metals and alloys for various purposes.....	33
2.9. Nanotechnological materials and nanotechnologies	38
Chapter 3. Semiconductor materials	42
3.1. Intrinsic and impurity semiconductors.....	42
3.2. Temperature dependence of the concentration of current carriers and specific conductivity in semiconductors	43
3.3. Mobility of current carriers in semiconductors.....	46
3.4. Kinetic effects in semiconductors	48
a) Electrical conductivity	48

b) Hall effect	49
c) Change of resistance in a magnetic field	50
d) Piezoresistance effect.....	51
e) Thermo-EMF	52
3.5. Classification of semiconductor materials	53
3.6. The most common semiconductor materials: silicon, germanium, gallium arsenide, etc.	55
Chapter 4. Dielectrics	66
4.1 General information	66
4.2. Polarization of dielectrics.....	66
4.3. Bias currents and electrical conductivity of dielectrics	68
4.4. Dielectric losses in dielectrics.....	69
4.5. Electrical breakdown of dielectrics.....	71
4.6. Breakdown of solid dielectrics.....	71
4.7. Passive dielectrics. Application of passive dielectric materials.....	73
4.8. Active dielectrics.....	80
a) Classification of active dielectrics	80
b) Ferroelectrics	80
c) Piezoelectrics	82
d) Pyroelectrics	84
e) Liquid crystals.....	85
Chapter 5. Magnetic materials	88
5.1. General concepts of magnetism	88
5.2. Classification of magnetic materials.....	88
5. 3. Ferromagnets.....	90
5.4. Magnetically soft materials.....	92
5.5. Magnetically hard materials.....	94

Appendix 96
Bibliography 102

..

FOR AUTHOR USE ONLY

**More
Books!**



yes
I want morebooks!

Buy your books fast and straightforward online - at one of world's fastest growing online book stores! Environmentally sound due to Print-on-Demand technologies.

Buy your books online at
www.morebooks.shop

Kaufen Sie Ihre Bücher schnell und unkompliziert online – auf einer der am schnellsten wachsenden Buchhandelsplattformen weltweit! Dank Print-On-Demand umwelt- und ressourcenschonend produziert.

Bücher schneller online kaufen
www.morebooks.shop



info@omniscryptum.com
www.omniscryptum.com

OMNIScriptum

